

# OPERATING MANUAL

## **VERSO**

### **6 PS | 7 PS | 8 PS | 9 PS**

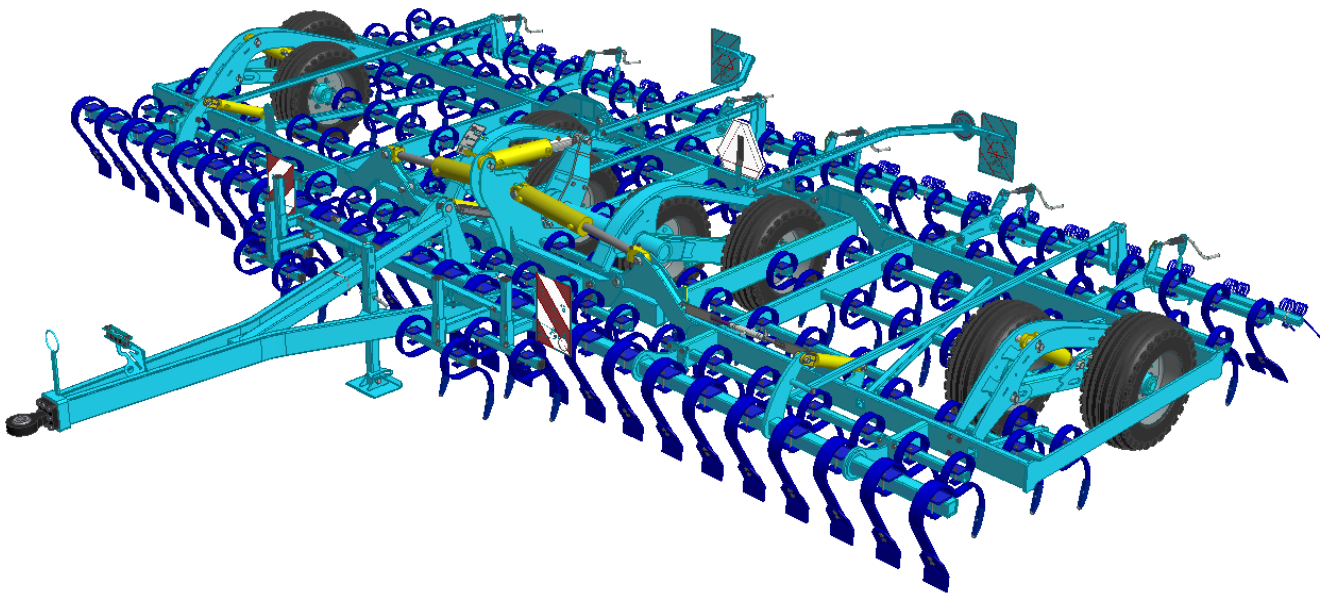

Edition: 7 | effective from: 1. 1. 2022

Dear Customer,

The **VERSO** semi-carried cultivators are high-quality products by Farnet a.s. Česká Skalice

You can fully utilise the advantages of your machine after thoroughly studying the operating manual.

The serial number of the machine is punched on the production label and written in the operating manual (see Table 1). This machine serial number must be stated whenever ordering spare parts for possible repairs. The production label is located on the middle frame near the tow bar.

Use only spare parts for these machines according to the **Spare parts catalogue** officially issued by the manufacturer, Farnet a.s. Ceska Skalice.

#### **Possibilities of Use of the machine**

The **VERSO** cultivator is designed for presowing preparation of soil as following operation after tillage or stubble cultivation with incorporation of plant residues up to depth of 10 cm (3.9 in).

Production label of the machine VERSO

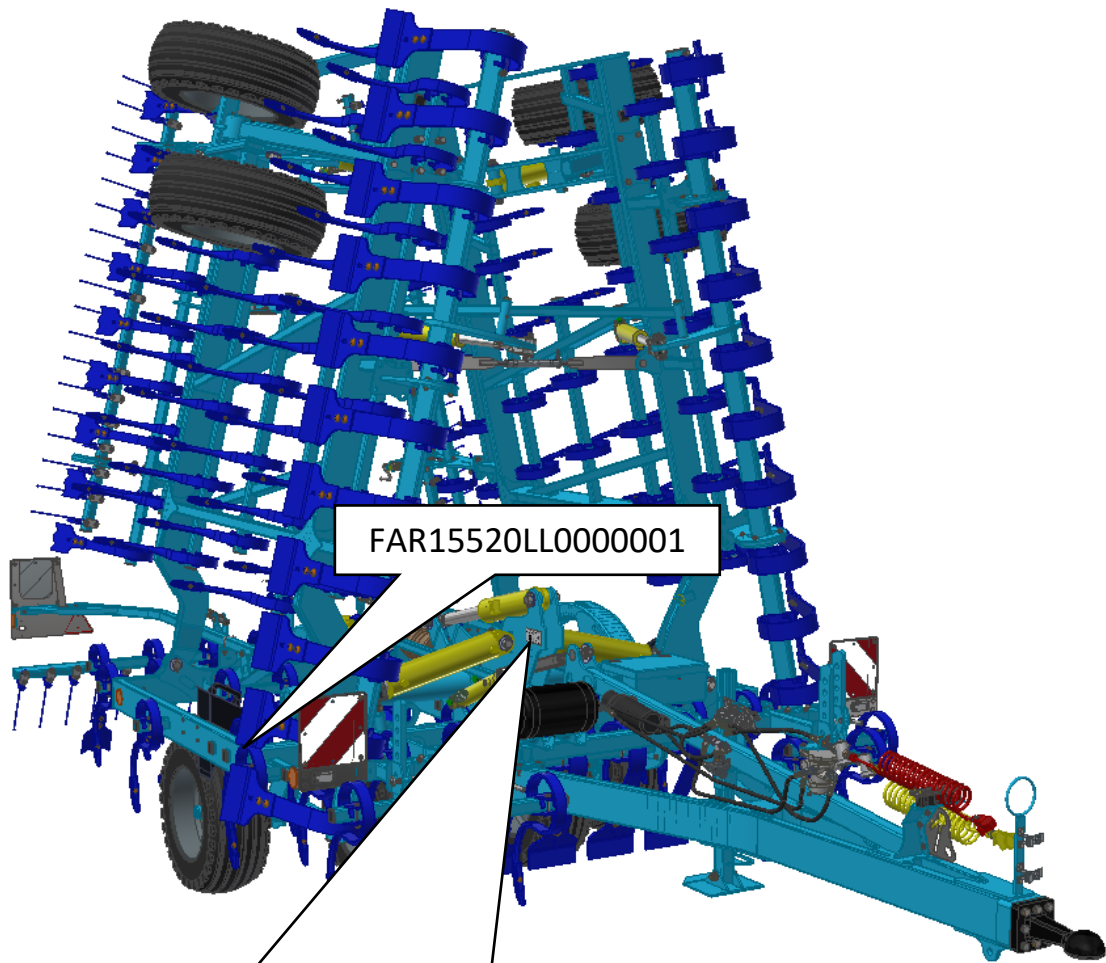

**A** FARMET a.s.

**B** S1a

**C** e8\*167/2013\*????\*00

**C** FAR15520LL0000001

**D** 3 850 kg

**E** A-0: 3 000 kg

**E** A-1: 1 540 kg

**F** A-2: 2 310 kg

**F** A-3: ---- kg

**G**

**H**

**I**

Jiřínková 276  
552 03 Česká Skalice  
www.farmet.cz  
MADE IN CZECH REPUBLIC

VERSO VRS8PS

|                                    |                                    |
|------------------------------------|------------------------------------|
| ROK VÝROBY /<br>YEAR OF PRODUCTION | CELKOVÁ HMOTNOST /<br>TOTAL WEIGHT |
| 2020                               | 4 200 kg                           |

|     |     |     |     |
|-----|-----|-----|-----|
| kg  | T-1 | T-2 | T-3 |
| B-1 | --- | --- | --- |
| B-2 | --- | --- | --- |
| B-3 | --- | --- | --- |
| B-4 | --- | --- | --- |

Self adhesive statutory plate 70x140

| <b>FARMET a.s.</b><br><b>S2a</b><br>e8*167/2013*?????*00<br><b>FAR15520VL0001114</b><br>3 850 kg<br>A-0: 3 000 kg<br>A-1: 1 540 kg<br>A-2: 2 310 kg<br>A-3: ---- kg |     | Jiřínková 276<br>552 03 Česká Skalce<br>www.farmet.cz<br>MADE IN CZECH REPUBLIC   |     |    |     |     |     |     |     |     |     |     |     |     |     |     |     |     |     |     |     |     |     |
|---|-----|---|-----|----|-----|-----|-----|-----|-----|-----|-----|-----|-----|-----|-----|-----|-----|-----|-----|-----|-----|-----|-----|
| <b>VERSO VRS8PS</b>   |     | CELKOVÁ HMOTNOST /<br>TOTAL WEIGHT<br><b>4 200 kg</b>   |     |    |     |     |     |     |     |     |     |     |     |     |     |     |     |     |     |     |     |     |     |
| ROK VÝROBY /<br>YEAR OF PRODUCTION<br><b>2020</b>   |     | <table border="1"> <thead> <tr> <th>kg</th> <th>T-1</th> <th>T-2</th> <th>T-3</th> </tr> </thead> <tbody> <tr> <td>B-1</td> <td>---</td> <td>---</td> <td>---</td> </tr> <tr> <td>B-2</td> <td>---</td> <td>---</td> <td>---</td> </tr> <tr> <td>B-3</td> <td>---</td> <td>---</td> <td>---</td> </tr> <tr> <td>B-4</td> <td>---</td> <td>---</td> <td>---</td> </tr> </tbody> </table> |     | kg | T-1 | T-2 | T-3 | B-1 | --- | --- | --- | B-2 | --- | --- | --- | B-3 | --- | --- | --- | B-4 | --- | --- | --- |
| kg  | T-1 | T-2   | T-3 |    |     |     |     |     |     |     |     |     |     |     |     |     |     |     |     |     |     |     |     |
| B-1   | --- | ---   | --- |    |     |     |     |     |     |     |     |     |     |     |     |     |     |     |     |     |     |     |     |
| B-2   | --- | ---   | --- |    |     |     |     |     |     |     |     |     |     |     |     |     |     |     |     |     |     |     |     |
| B-3   | --- | ---   | --- |    |     |     |     |     |     |     |     |     |     |     |     |     |     |     |     |     |     |     |     |
| B-4   | --- | ---   | --- |    |     |     |     |     |     |     |     |     |     |     |     |     |     |     |     |     |     |     |     |
|   |     |   |     |    |     |     |     |     |     |     |     |     |     |     |     |     |     |     |     |     |     |     |     |
|   |     |   |     |    |     |     |     |     |     |     |     |     |     |     |     |     |     |     |     |     |     |     |     |

|          |   |
|----------|---|
| <b>A</b> | Vehicle category according to R167/2013   |
| <b>B</b> | Approval number   |
| <b>C</b> | Seventeen-digit serial number (VIN)   |
| <b>D</b> | Technically permissible maximum laden mass of the vehicle   |
| <b>E</b> | Maximum vertical load on the coupling point   |
| <b>F</b> | Permissible load – axle 1   |
| <b>G</b> | Permissible load – axle 2   |
| <b>H</b> | Permissible load – axle 3   |
| <b>I</b> | Technically permissible towable mass for each chassis/braking configuration for R or S category vehicle |
| <b>1</b> | Commercial name, general description and purpose  |
| <b>2</b> | Total weight  |
| <b>3</b> | Year of production  |

**AXLE IDENTIFICATION**

The factory number of the axle shaft and its typ are stamped onto the identification plate.

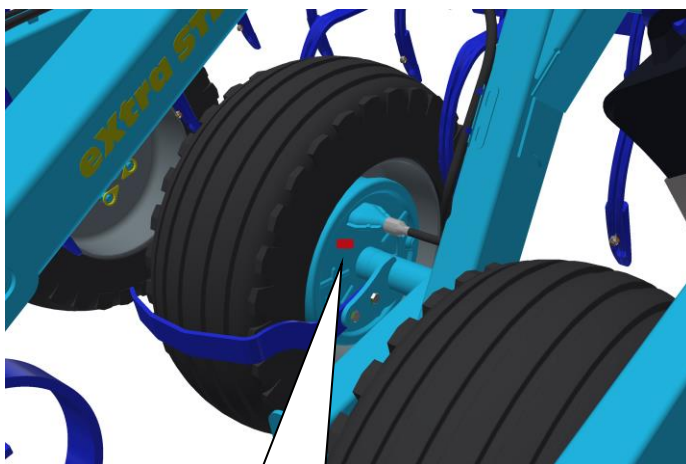

Identification plate

Identification plate:

**KNOTT type: 726176, BRAKE 30-2355 (300x60)**



A

**ALKO type: ID RIGHT AND LEFT 1909977, BRAKE 3081B (300x80)**

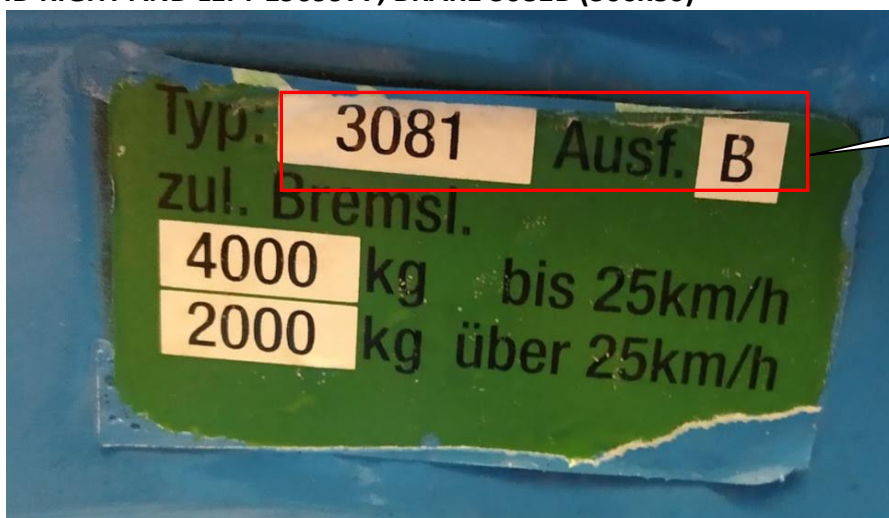

B

The axle identification plate can be read as follows:

- A: axle identification code
- B: brake identification code

Table 1 – Your Machine Characteristics

|                                      |  |
|--------------------------------------|--|
| <b>MACHINE TYPE</b>                  |  |
| <b>MACHINE SERIAL NUMBER</b>         |  |
| <b>SPECIAL DESIGN OR ACCESSORIES</b> |  |
| .....                                |  |
| .....                                |  |
| .....                                |  |

## TABLE OF CONTENTS

|   |    |
|---|----|
| MACHINE LIMIT PARAMETERS .....                              | 7  |
| Technical parameters .....                                  | 7  |
| Safety statement .....                                      | 7  |
| A. GENERAL INSTRUCTIONS FOR USE .....                       | 8  |
| Protective tools .....                                      | 8  |
| B. MACHINE TRANSPORT USING TRANSPORT MEANS .....            | 9  |
| C. MACHINE HANDLING USING LIFTING EQUIPMENT .....           | 9  |
| D. WORK SAFETY LABELS .....                                 | 9  |
| 1. DESCRIPTION .....  | 13 |
| Work parts of the machine .....                             | 13 |
| Brake system .....  | 13 |
| Lighting system .....                                       | 15 |
| 2. MACHINE ASSEMBLY AT THE CUSTOMER .....                   | 17 |
| 3. COMMISSIONING .....                                      | 17 |
| 3.1 Agregation to a tractor .....                           | 18 |
| 3.2 Hydraulics connection .....                             | 19 |
| 3.3 Folding and unfolding of the machine .....              | 23 |
| 3.3.1 Folding the machine into the transport position ..... | 23 |
| 3.3.2 Unfolding the machine into the working position ..... | 24 |
| 4. MACHINE TRANSPORT ON ROADS .....                         | 26 |
| 4.1 Sharp machine projection .....                          | 27 |
| 5. MACHINE ADJUSTMENT .....                                 | 28 |
| 5.1 Adjusting the working depth of the machine .....        | 28 |
| 5.1.1 Adjusting the depth indicator .....                   | 28 |
| 5.1.2 Adjusting the working depth .....                     | 29 |
| 5.2 Adjusting the longitudinal level of the machine .....   | 30 |
| 5.3 Adjusting the track cultivator .....                    | 31 |
| 5.4 Adjusting the flexi-board .....                         | 32 |
| 5.5 Adjustment the leveller .....                           | 34 |
| 6. MACHINE MAINTENANCE AND REPAIRS .....                    | 35 |
| 7. MACHINE STORAGE .....                                    | 45 |
| 8. MACHINE LUBRICATION SCHEDULE .....                       | 46 |
| 9. ENVIRONMENTAL PROTECTION .....                           | 48 |
| 10. MACHINE DISPOSAL AFTER SERVICE LIFE EXPIRY .....        | 48 |
| 11. SERVICING AND WARRANTY CONDITIONS .....                 | 48 |
| 11.1 Servicing .....  | 48 |
| 11.2 Warranty .....   | 48 |
| CE Certificate of Conformity .....                          | 49 |



## MACHINE LIMIT PARAMETERS

- <sup>(x)</sup> The machine is designed for tilling soil in agriculture. It is used for presowing preparation of soil after tillage and stubble cultivation – to level the surface and to prepare the sowing bed. The processing depth is up to 10cm (3.9 in). Another type of use exceeding the determined purpose is forbidden.
- <sup>(x)</sup> The machine is only operated by one person – the tractor driver.
- <sup>(x)</sup> Machine operator must not use the machine in a different way, especially:
  - <sup>(x)</sup> Transport of persons and animals on the machine structure,
  - <sup>(x)</sup> Transport of burdens on the machine structure,
  - <sup>(x)</sup> Aggregation of the machine with another towing equipment than stated in Chapter "3.1./p. 18".

## TECHNICAL PARAMETERS

Table 2 – Technical Parameters

| PARAMETERS                             | VERSO 6                    | VERSO 7                  | VERSO 8                      | VERSO 9                       |
|--|----------------------------|--------------------------|------------------------------|-------------------------------|
| Working width (mm)                     | 6 000 (19,69 ft)           | 7 000 (22,97 ft)         | 8 000 (26,25 ft)             | 9 000 (29,53 ft)              |
| Transport width (mm)                   | 3 000 (9,84 ft)            |                          |                              |                               |
| Transport height (mm)                  | 3 160 (10,37 ft)           | 3 720 (12,2 ft)          | 4 000 (13,12 ft)             | 4 580 (15 ft)                 |
| Machine total length (mm)              | 6 830 (22,41 ft)           |                          |                              |                               |
| Working depth (mm)                     | 0–100 (0-3,9 in)           |                          |                              |                               |
| Number of chisels (+Track Cultivators) | 77 (+8)                    | 91 (+8)                  | 101 (+8)                     | 115 (+8)                      |
| Working performance (ha/h)             | 4,8-7,2<br>(11,9-17,8ac/h) | 5,7 - 8,5<br>(14-21ac/h) | 6,4 - 9,6<br>(15,8-23,7ac/h) | 7,2 - 10,9<br>(17,8-26,9ac/h) |
| Towing means (kW)                      | 130–195*<br>(175-260HP)    | 150–225*<br>(200-300HP)  | 160–240*<br>(215-320HP)      | 180–270*<br>(240-360HP)       |
| Working speed (kph)                    | 8–12<br>(5-7,5mph)         |                          |                              |                               |
| Maximum transport speed (kph)          | 20 (12,4mph)               |                          |                              |                               |
| Maximum slope grade (°)                | 6                          |                          |                              |                               |
| Tyre dimensions - transport            | 10.0/75-15,3 14PR          |                          |                              |                               |
| Tyre pressure (kPa)                    | 550 kPa (80 Psi)           |                          |                              |                               |
| Machine weight (kg)                    | 3570 (7871 lb)             | 3920 (8642 lb)           | 3960 (8730 lb)               | 4350 (9590 lb)                |

\* Recommended towing means, the real towing force may significantly vary according to the processing depth, soil conditions, land slope, working body wear and adjustment

## SAFETY STATEMENT

|  |   |
|--|---|
|  | This warning sign warns about an immediate dangerous situation ending with death or severe injury.  |
|  | This warning sign warns about a dangerous situation ending with death or severe injury.   |
|  | This warning sign warns about a situation that may end with a smaller or slight injury. It also warns about dangerous actions related to the activity that could lead to an injury. |

## A. GENERAL INSTRUCTIONS FOR USE

**A.1** <sup>(x)</sup> The machine is made in accordance with the latest equipment state and approved safety regulations. However, dangers of user or third person injury or machine damage or creation of other material damage may arise during use.

**A.2** <sup>(xx)</sup> Use the machine only in a technically sound condition, in accordance with its purpose, aware of possible dangers, and while adhering to the safety instructions of this operating manual!  
The Manufacturer is not liable for damages caused by the use of the machine that is in contradiction with the limit parameters of the machine (p. 7) and with the instructions for the use of the machine (Chapter A and 3). The User bears the risk.  
Immediately remove especially the failures that may negatively affect safety!

**A.3** <sup>(7)</sup> Machine operation may be performed by a person authorised by the operator under these conditions:

- <sup>(8)</sup> It must own a valid driver's licence of the corresponding category,
- <sup>(9)</sup> It must be demonstrably familiarised with the safety regulations for work with the machine and must practically master the machine operation,
- <sup>(10)</sup> The machine may not be operated by juveniles,
- <sup>(11)</sup> It must know the meaning of the safety signs located on the machine. Their respecting is important for safe and reliable machine operation.

**A.4** <sup>(12)</sup> Maintenance and servicing repairs on the machine may only be performed by a person:

- <sup>(13)</sup> Authorised by the operator,
- <sup>(14)</sup> Educated in the machinery field with knowledge of repairs of similar machines,
- <sup>(15)</sup> Demonstrably familiarised with safety regulations for work with the machine,
- <sup>(16)</sup> During a repair of a machine connected to a tractor, it must own a driver's licence of the corresponding category.

**A.5** <sup>(17)</sup> Machine operator must secure the safety of other persons when working with the machine or transporting the machine.

**A.6** <sup>(18)</sup> During machine work in the field or during transport, the operator must control the machine from the tractor's cabin.

 **A.7** <sup>(19)</sup> The operator may enter the machine structure only with the machine at rest and blocked against movement, namely only for these reasons:

- <sup>(20)</sup> Adjustment of the machine working parts,
- <sup>(21)</sup> Repair and maintenance of the machine,
- <sup>(29)</sup> Release and securing of spherical valves of the axle,
- <sup>(27)</sup> Securing of spherical valves of the axle before folding the side frames,
- <sup>(28)</sup> Adjustment of the working parts of the machine after unfolding the side frames.

 **A.8** <sup>(xxx)</sup> When stepping on the machine, do not step on tyres or other rotary parts. Those may turn and you can cause very serious injuries by the subsequent fall.

 **A.9** <sup>(22)</sup> Any changes or modifications of machine may be performed only with written consent of the manufacturer. For possible damage arisen due to ignoring this instruction, the producer bears no responsibility. The machine must be maintained equipped with prescribed accessories and equipment including safety marking. All warning and safety signs must be legible and in their places. In case of damage or loss, these signs must be immediately renewed.

**A.10** <sup>(23)</sup> The operator must have the Operating Manual with the work safety requirements available at any time when working with the machine.

 **A.11** <sup>(24)</sup> The operator must not consume alcohol, medicines, narcotic and hallucinogenic substances that decrease his attention and coordination capabilities while using the machine. If the operator must use medicines prescribed by a physician or uses freely sold medicines, he must be informed by a physician, whether he is capable of responsible and safe operation of the machine under these circumstances.

### **PROTECTIVE TOOLS**

For the operation and maintenance use:

- Tight clothes
- Protective gloves and goggles for protection against dust and sharp parts of the machine.







## B. MACHINE TRANSPORT USING TRANSPORT MEANS

- B.1** <sup>(1)</sup> The transport means designed for machine transport must have the load capacity minimally identical with the weight of the transported machine. The total weight of the machine is stated on the production label.
- B.2** <sup>(2)</sup> The dimensions of the transported machine including the transport means must comply with the valid regulations for road traffic (decrees, laws).
-  **B.3** <sup>(3)</sup> The transported machine must be always fastened to the transport means so that its spontaneous loosening could not happen.
- B.4** <sup>(4)</sup> The carrier is responsible for damage caused by the loosening of incorrectly or insufficiently fastened machine to the transport means.

## C. MACHINE HANDLING USING LIFTING EQUIPMENT

- C.1** <sup>(1)</sup> The lifting equipment and tying means designed for handling of the machine must have their load capacity at least identical with the weight of the handled machine.
-  **C.2** <sup>(2)</sup> Machine fastening for handling may only be performed in places designed for that and marked with self-adhesive labels showing the "chain" symbol.  “.
- C.3** <sup>(3)</sup> After fastening (suspending) at designated points, it is forbidden to move in the space of possible reach of the handled machine.

### C.4 Chart of informational weights of parts according to the load version

|  | VERSO6PS | VERSO7PS | VERSO8PS | VERSO9PS |
|--|----------|----------|----------|----------|
| TOW BAR (kg)                             | 350      | 350      | 350      | 350      |
| MACHINE FOUNDATION (kg)                  | 2400     | 2650     | 2700     | 2960     |
| REAR FLEXI-BOARDS+CENTRAL LEVELLING (kg) | 200      | 200      | 200      | 200      |
| REAR FLEXI-BOARDS+SIDE LEVELLING (kg)    | 180      | 190      | 200      | 210      |
| FRONT SIDE FLEXI BOARDS (kg)             | 180      | 190      | 200      | 210      |
| ENTIRE MACHINE (kg)                      | 3570     | 3920     | 3960     | 4350     |

## D. WORK SAFETY LABELS

Warning safety labels serve for operator protection.

### General:

- A) Strictly observe the warning safety labels.
- B) All safety instructions also apply to other users.
- C) Upon damage or destruction of the aforementioned "SAFETY LABEL" located on the machine, THE OPERATOR IS OBLIGED TO REPLACE IT WITH A NEW ONE!!!

The position, appearance, and precise meaning of work safety labels on the machine is determined in the following tables (Tab.3/p. 10-11) and in the figure (Fig.2/p.12).

Table 3 – Self-adhesive warning safety labels located on the machine

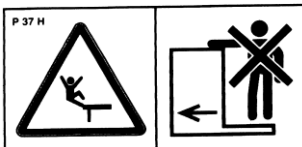
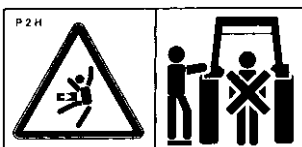
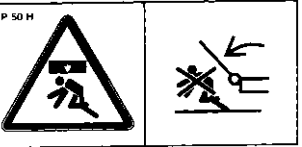
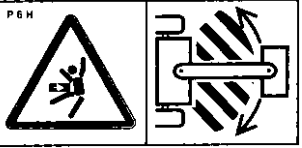
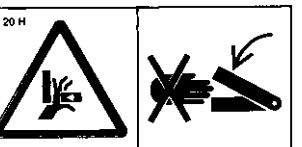
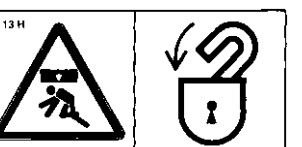
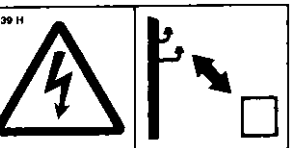
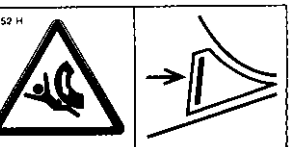
| WARNING SAFETY LABEL  | LABEL TEXT   | MACHINE POSITION     |
|---|--|----------------------|
|    | <p>Before handling the machine, carefully read the operating manual. Observe the instructions and safety regulations for machine operation during use.</p>   | <p><b>P 1 H</b></p>  |
|    | <p>Travelling and transport on the machine structure is strictly forbidden.</p>  | <p><b>P 37 H</b></p> |
|    | <p>When connecting or disconnecting, do not step between the tractor and the machine, also do not enter this space, if the tractor and the machine are not at rest and the engine is not turned off.</p> | <p><b>P 2 H</b></p>  |
|    | <p>When folding and unfolding the side frames, stay outside their reach.</p>   | <p><b>P 50 H</b></p> |
|  | <p>Stay outside the reach of the tractor - agricultural machine set, if the tractor engine is in operation.</p>  | <p><b>P 6 H</b></p>  |
|  | <p>When folding the side frames, do not reach into the space of the machine folding joints.<br/>There is a danger of cutting when setting the depth of the machine.</p>                                  | <p><b>P 20 H</b></p> |
|  | <p>Before commencing the machine transport, secure the frames with a connecting rod</p>  | <p><b>P 13 H</b></p> |
|  | <p>When working and transporting the machine, maintain safe distance from the electric appliances.</p>   | <p><b>P 39 H</b></p> |
|  | <p>Secure the machine against unwanted movement by positioning on its working bodies (chisels).</p>  | <p><b>P 52 H</b></p> |

|  |  |                       |
|--|--|-----------------------|
|  | <p>Do not approach the rotary parts of the machine, if these are not at rest, i.e. they do not turn.</p>         | <p><b>P 53 H</b></p>  |
|  | <p>It is strictly folding and unfolding the side frames on slopes or inclined surfaces.</p>                      | <p><b>P 100 H</b></p> |
|  | <p>The shown positions of the handle and the function of the hydraulic ball valve located on the piston-rod.</p> | <p><b>P 101 H</b></p> |

Fig.2- Location of safety labels on the VERSO

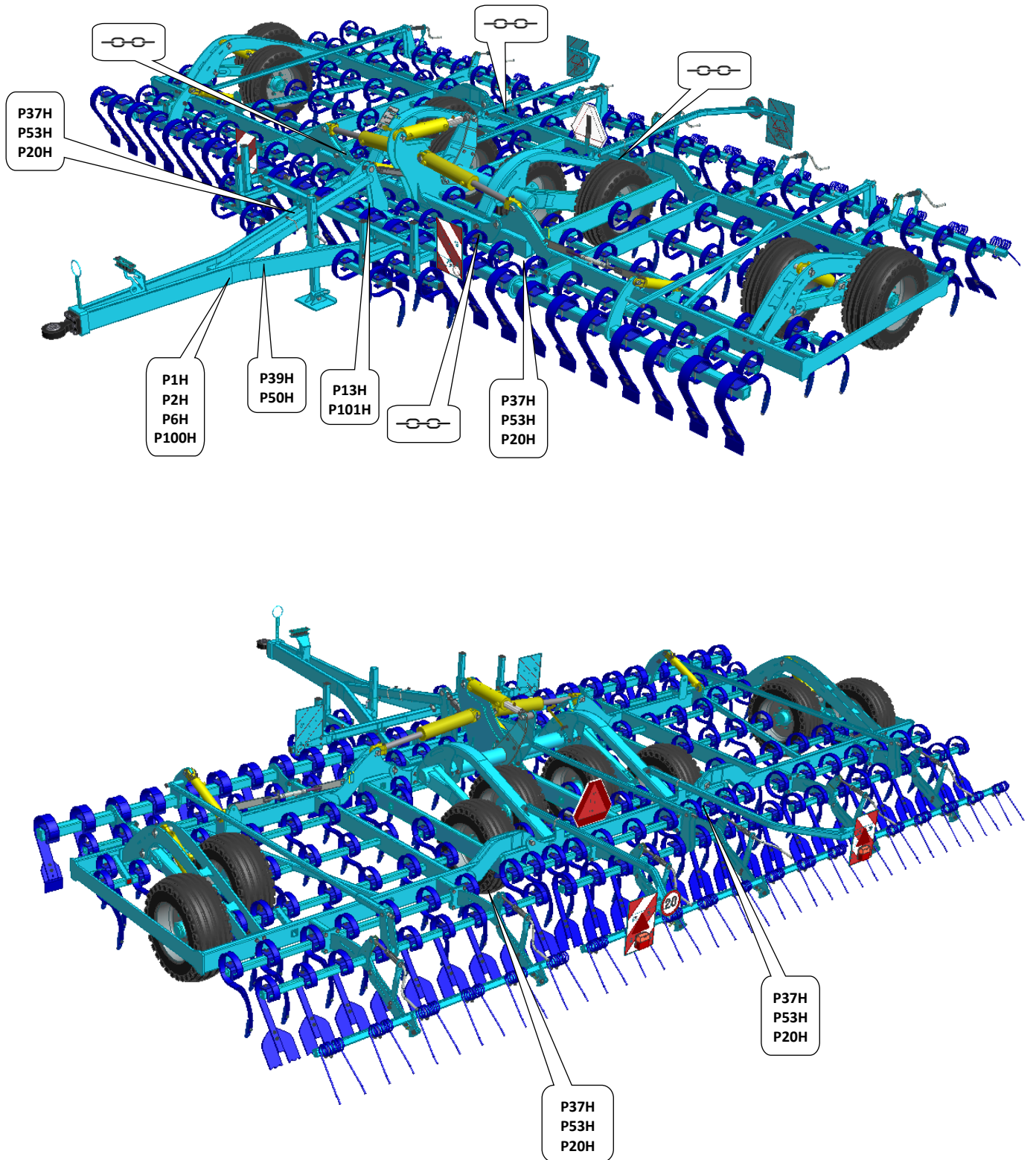

## 1. DESCRIPTION

VERSO is structurally designed as a semi-carried folding machine. The basic version consists of a towing fork with a connecting loop, 51 mm in diameter, or 40-mm loop, 71-mm loop, or with the K80 hitch, or a traction bar for the two-point hitch with revolving pins Ø36mm for Category TPS3. Furthermore, the machine consists of a central frame with the transport axle and two side frames. There are five rows of flexible shares on the central and side frames. There is a blade leveller – Flexi-board in front of the first row of shares. There is an additional Flexi-board and flexible levelling springs installed after the last row of ploughshares.

### WORK PARTS OF THE MACHINE

Fig.3- Work Parts of the Machine

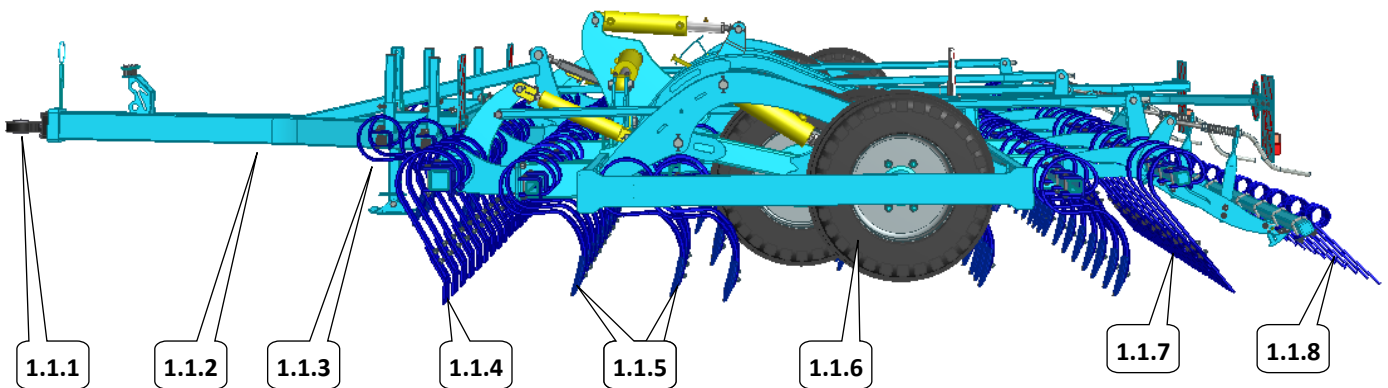

- |  |  |
|--|--|
| <b>1.1.1</b> Towing loop                               | <b>1.1.5</b> Five rows of flexible shares    |
| <b>1.1.2</b> Towing fork with a supporting folding leg | <b>1.1.6</b> Supporting and transport wheels |
| <b>1.1.3</b> Track cultivators                         | <b>1.1.7</b> Rear Flexi-board                |
| <b>1.1.4</b> Front Flexi-board                         | <b>1.1.8</b> Rear harrow springs             |

### BRAKE SYSTEM

Service brake: pneumatic brake two-hose, without load control of braking force

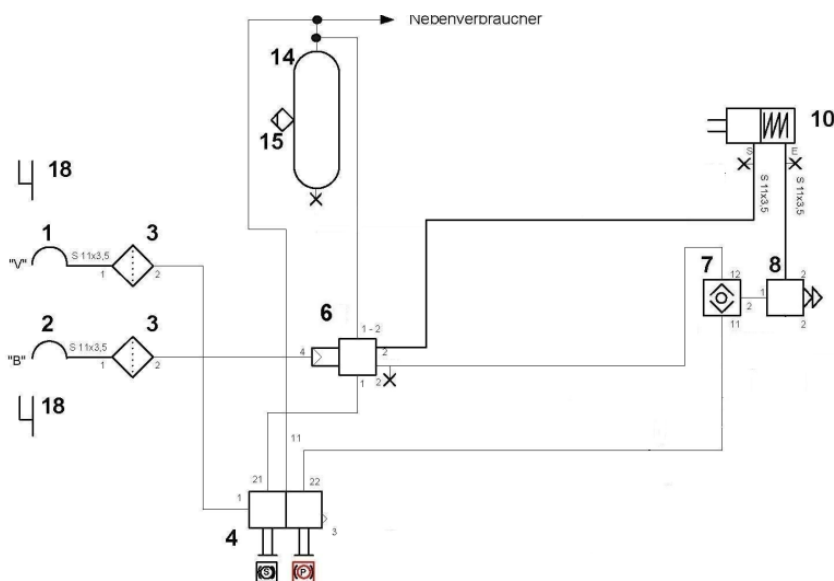

- (1) Quick-coupler – red line, (2) Quick-coupler – yellow line, (3) Air filter, (4) control valve of the manual brake, (6) Brake valve, (7) Two-way valve, (8) Jettisoning valve, (10) Combined membrane brake cylinder, (14) Air tank 40l, (15) drain valve, (18) Quick-coupler holder

### Connection

1. **Connect the** Coupling head "Brake" (yellow) **first**.
2. **Then connect the** Coupling head "Provision" (red).
3. Release the parking brake.

### Unhitching

1. Apply the parking brake.
2. **First disconnect the** Coupling head "Provision" (red).
3. **Then disconnect the** Coupling head "Brake" (yellow).

### Parking brake: Hand brake control valve

- The rear axle brakes are equipped with an automatic manual brake, the function of which is described below

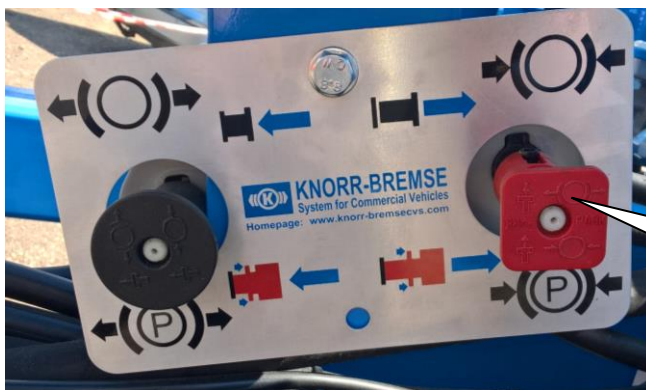

CONTROL BUTTON OF  
THE MANUAL BRAKE

### Description of the manual brake



RED BUTTON PRESSED  
=  
MANUAL BRAKE IS NOT ACTIVE  
(THE MACHINE IS RELEASED)

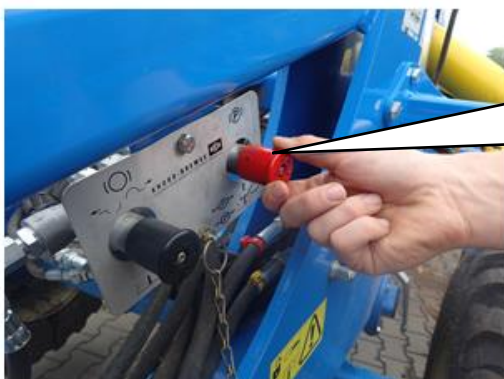

RED BUTTON EXTRACTED  
=  
MANUAL BRAKE IS ACTIVE  
(THE MACHINE IS BRAKED)



### Emergency brake release in case of air leak



- It is possible to release the brakes of the machine using special brake release bolts in case of a leak of air from the brake system.
- The bolts are included in the installation unit of the brake cylinder.

### **Emergency brake release procedure in case of air leak**

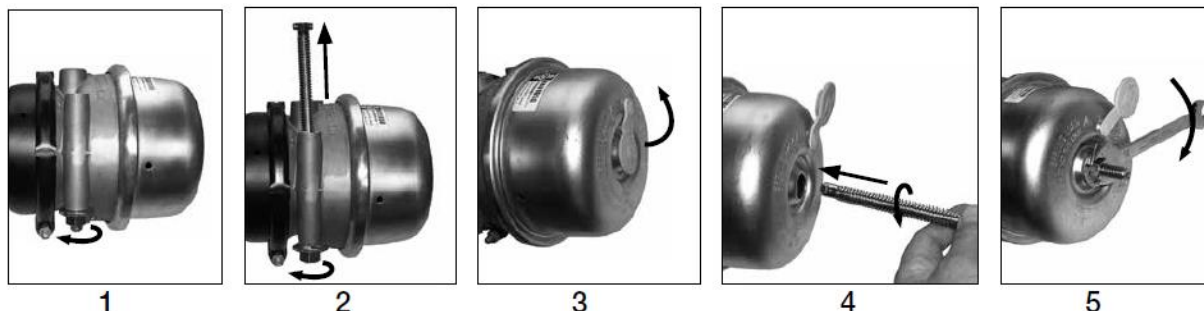

- Remove the bolts from the holders of the brake cylinder (Fig. 1 and 2)
- Release the cap on the back side of the brake cylinder (Fig. 3)
- Insert the bolt by its flat end (T-shape) into the opening in the cylinder and turn the bolt by 90° at the end of the opening so that the screw is arrested and cannot be pulled out (Fig.4)
- Turn the nut (19 mm spanner) clockwise (Fig.5). ATTENTION: Maximum torque is limited to 68Nm

## **LIGHTING SYSTEM**

The electrical system is designed for supply of 12 V DC.

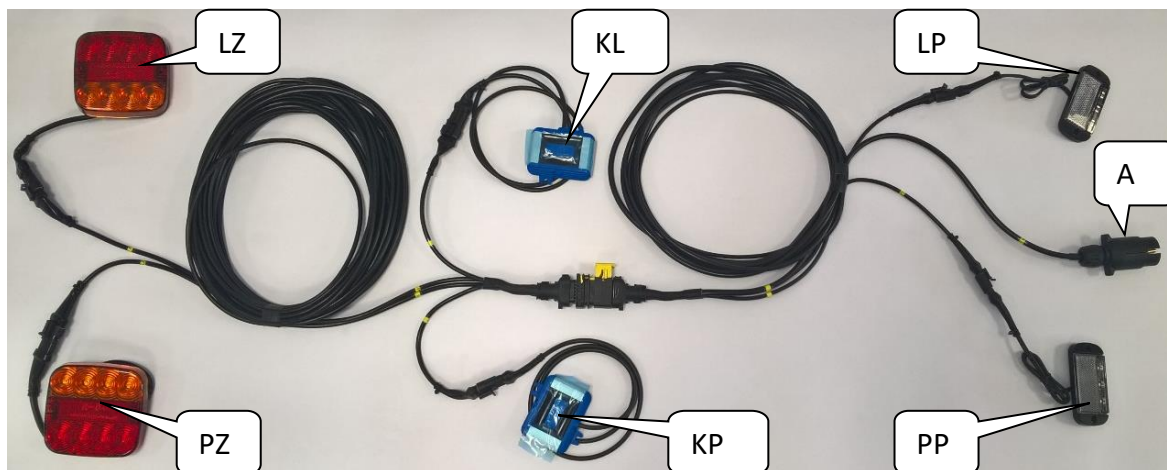

| SYMBOL | NAME                    |
|--------|-------------------------|
| A      | 7-pin socket (ISO 1724) |
| LP     | Front left lamp         |
| PP     | Front right lamp        |
| KL     | Left „controller“       |
| KP     | Right „controller“      |
| LZ     | Rear left lamp          |
| PZ     | Rear right lamp         |

A: 7-pin socket connection markings (ISO 1724)

| No. | MARKING | FUNKCION         |
|-----|---------|------------------|
| 1   | L       | Left indicator   |
| 2   | 54G     | -                |
| 3   | 31      | Earth            |
| 4   | R       | Right indicator  |
| 5   | 58R     | Rear right light |
| 6   | 54      | Brake light      |
| 7   | 58L     | Rear left light  |

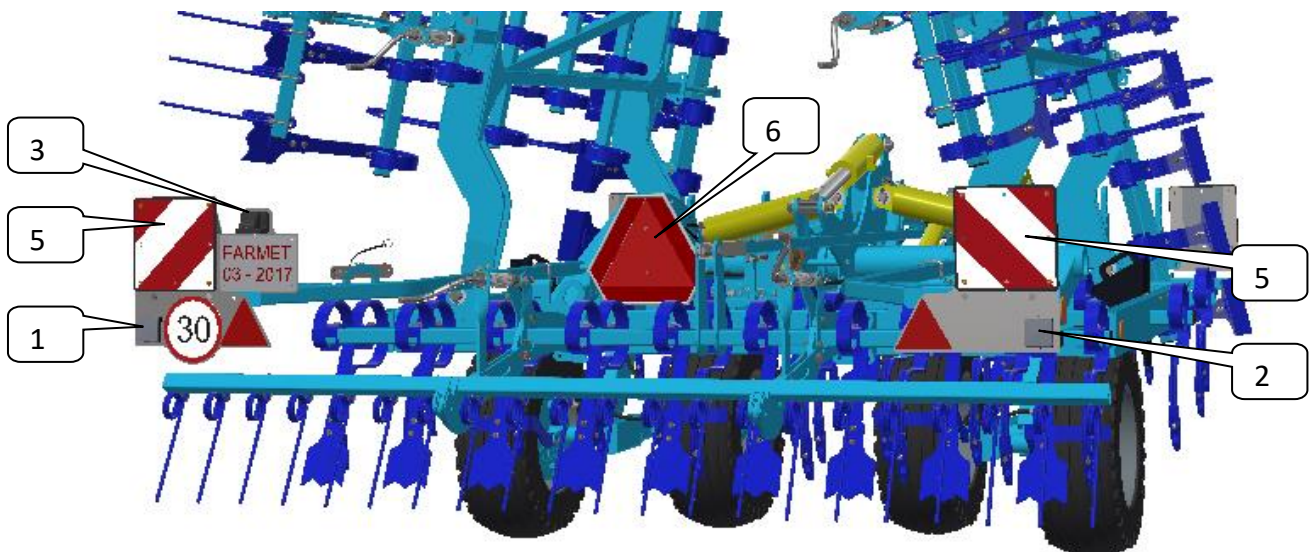
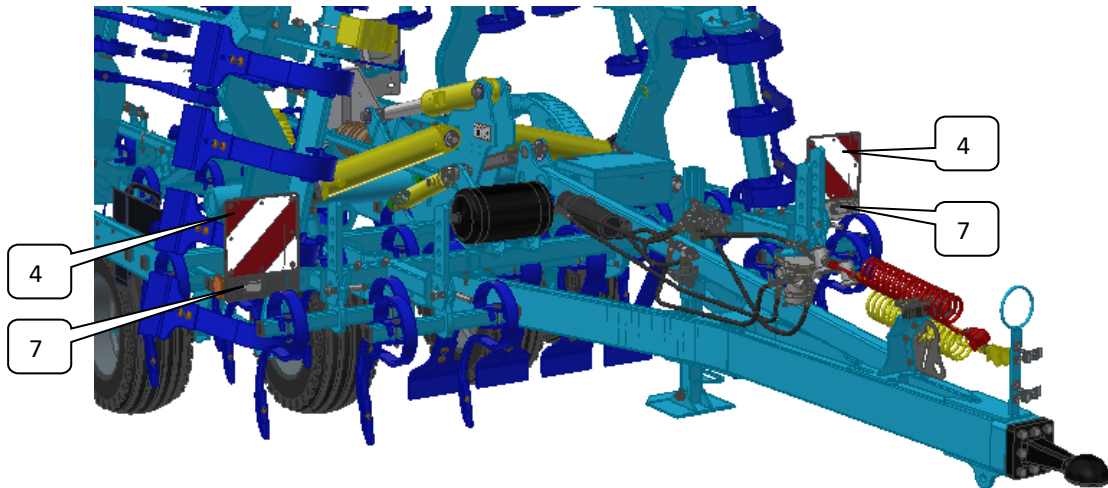
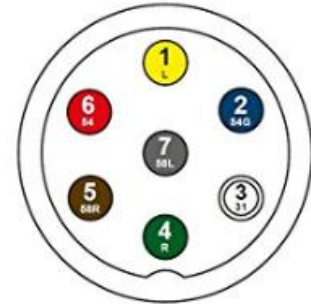

| Pos. | Arrangement of electrical system components |
|------|---|
| 1    | Rear left lamp                              |
| 2    | Rear right lamp                             |
| 3    | Licence plate light                         |
| 4    | Front warning board                         |
| 5    | Rear warning board                          |
| 6    | Rear warning board (EHK OSN 69)             |
| 7    | Front white lamp with reflector             |

## 2. MACHINE ASSEMBLY AT THE CUSTOMER



- The operator must perform the assembly according to the instructions of the producer, best in cooperation with the expert servicing technician determined by the producer.
- The operator must secure a functional test of all assembled parts after the completion of the machine assembly.
- The operator must secure that the handling of the machine using lifting equipment during its assembly is in accordance with chapter "C".

## 3. COMMISSIONING



- Before taking over the machine, test and check, whether damage occurred during transport and whether all parts contained in the bill of delivery were supplied.
- Before commissioning the machine, carefully read this operating manual, especially Chapters **A-D** p. 8-12. Before the first use of the machine, familiarise yourselves with its controls and overall function.
- During work with the machine, observe not only the instructions of these operating manual but also generally valid regulations of work safety, health protection, fire and transport safety, and environmental protection.
- The operator must check the machine before every use (commissioning) from the standpoint of completeness, work safety, work hygiene, fire safety, transport safety, and environmental protection.  
A machine showing signs of damage must not be commissioned.
- Aggregation of the machine with the tractor is to be performed on a flat and hardened surface.
- When working on slopes, observe the lowest allowable slope grade of the set **TRACTOR - MACHINE**.
- Before starting the tractor motor, check whether no person or animal is in the working space of the set and push the warning sound signal.
- The operator is responsible for the safety and all damage caused by the operation of the tractor and the connected machine.
- The operator is obliged to adhere to the technical and safety regulations of the machine determined by the producer when working.
- When turning the machine at headland, the operator must lift the machine, i.e. the working bodies are not in the ground.
- The operator is obliged to observe the prescribed working depths and speeds stated in the manual in Table 2/p. 7 when working with the machine.
- The operator is obliged to lower the machine to the ground and secure the set against movement before leaving the tractor cabin.

### **DECREASE OF SOIL PRESSURE TO A VALUE LOWER THAN 200kPa (29 Psi)**

- To decrease the specific pressure on soil (below 200kPa/29Psi) at the turns on the headland, raise the machine on the pole by using the hydraulic tractor shoulders and rear wheels. Turn around when the machine is unfolded and resting on all rear wheels.

### 3.1 AGREGATION TO A TRACTOR

- The machine can be connected only to a tractor, whose curb weight is identical or higher than the overall weight of the connected machine.
- The machine operator must observe all generally valid regulations of work safety, health protection, fire safety, and environmental protection.
- The operator may only attach the machine to a tractor equipped with a bottom hitch or a rear two-point hitch (according to the version of the machine) and with a functional and intact hydraulic system.
- The table of requirements for the towing means for work with the machine:

|  |                               |  |
|--|-------------------------------|--|
| Requirement for the tractor engine power for VERSO 6                     |                               | <b>130-195 kW (175-260 HP)</b>   |
| Requirement for the tractor engine power for VERSO 7                     |                               | <b>150-225 kW (200-300 HP)</b>   |
| Requirement for the tractor engine power for VERSO 8                     |                               | <b>160-240 kW (215-320 HP)</b>   |
| Requirement for the tractor engine power for VERSO 9                     |                               | <b>180-270 kW (240-360 HP)</b>   |
| Requirement for the tractor two-point hitch (according to configuration) | Hitch pin diameter            | <b>Ø36 mm (1,42 in)</b>  |
| Requirement for the bottom hitch (according to configuration)            | Towing ball                   | <b>K80</b>   |
|  | Towing loop                   | <b>Ø40 mm (1,6 in)<br/>Ø51 mm (2 in)<br/>Ø71 mm (2,8 in)</b>                           |
| Requirement for the hydraulic system of the tractor                      | Side frame folding circuit    | <b>Circuit pressure 200 bar (2900Psi),<br/>2 pcs of quick-coupler sockets ISO 12,5</b> |
|  | Flexi-board control circuit   | <b>Circuit pressure 200 bar (2900Psi),<br/>2 pcs of quick-coupler sockets ISO 12,5</b> |
|  | Machine lifting circuit       | <b>Circuit pressure 200 bar (2900Psi),<br/>2 pcs of quick-coupler sockets ISO 12,5</b> |
|  | Working depth setting circuit | <b>Circuit pressure 200 bar (2900Psi),<br/>2 pcs of quick-coupler sockets ISO 12,5</b> |



**When connecting, no persons may stay in the space between the tractor and the machine.**

Fig.4 – Hitch Versions

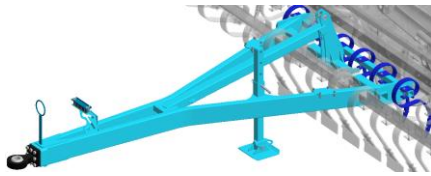
**VERSION – C40; C50; C70**

Aggregation of the machine to the fixed bottom hitch with a pulling loop with the diameter of 40mm, 50mm or 70mm.

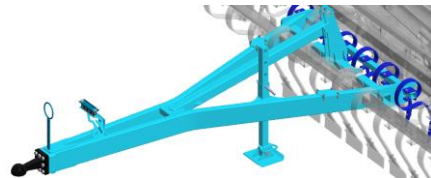
**VERSION – K80**

Aggregation of the machine to the fixed bottom hitch with a K80 ball.

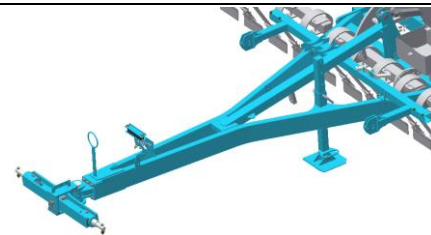
**VERSION – TBZ**

Aggregation of the machine to the TBZ 3 (three-point hitch) arms.

## 3.2 HYDRAULICS CONNECTION

- Connect the hydraulics only when the hydraulic circuits of the machine and the tractor (aggregate) are in a pressure-less condition.
- The hydraulic system is under high pressure. Regularly check for leaks and immediately remove obvious damage of all lines, hoses, and pipe unions.
- When seeking and removing leaks, use only the suitable tools.
- For connecting the hydraulic system of the machine to the tractor, use the plug (on the machine) and the socket (on the tractor) of the quick couplers of the same type. Perform the connection of the snap coupling of the machine to the hydraulic circuits of the tractor so that the folding of the side frames (**RED CIRCUIT**) is on one control circuit, axle lifting of the machine (**YELLOW CIRCUIT**) on the second control circuit, depth setting (**GREEN CIRCUIT**) on the third control circuit and Flexi-board control (**BLUE CIRCUIT**) on the fourth control circuit.
- For simplification, the hydraulic circuits are marked by different colours.
- Side frame folding (**RED CIRCUIT**)
- Lifting machine on the axle (**YELLOW CIRCUIT**)
- Working depth control (**GREEN CIRCUIT**)
- Flexi-board control (**BLUE CIRCUIT**)



In order to prevent accidental or foreign person (children, passengers) caused movement of the hydraulics, the control switchboards on the tractor must be secured or blocked in the transport position.



Parts of the hydraulic system of the machine, which are under pressure, are forbidden to disassemble. Hydraulic oil that penetrates the skin under high pressure causes severe injuries. In case of injury, seek a physician immediately.



|  |   |
|--|---|
|  | <p>HYDRAULIC CIRCUIT OF SIDE FRAME HOLDING<br/> <b>- ONE RED RING</b><br/>                 Pressurizing this branch of the circuit folds side frames into the transport position.</p>   |
|  | <p>HYDRAULIC CIRCUIT OF SIDE FRAME HOLDING<br/> <b>- TWO RED RINGS</b><br/>                 Pressurizing this branch of the circuit unfolds side frames into the working position.</p>  |
|  | <p>HYDRAULIC CIRCUIT FOR AXLE CONTROL<br/> <b>- ONE YELLOW RING</b><br/>                 Pressurizing this branch of the circuit brings the transport axle into the transport position, i.e. the working parts are in the highest position against the axle.</p>        |
|  | <p>HYDRAULIC CIRCUIT FOR AXLE CONTROL<br/> <b>- TWO YELLOW RINGS</b><br/>                 Pressurizing this branch of the circuit lifts the transport axle into the position when the working parts of the machine are in the set working depth against the wheels.</p> |
|  | <p>HYDRAULIC CIRCUIT FOR SHARE WORKING DEPTH CONTROL<br/> <b>- ONE GREEN RING</b><br/>                 Pressurizing this branch of the circuit brings shares out of the processed profile.</p>  |
|  | <p>HYDRAULIC CIRCUIT FOR SHARE WORKING DEPTH CONTROL<br/> <b>- TWO GREEN RINGS</b><br/>                 Pressurizing this branch of the circuit recesses shares into the processed profile.</p>   |
|  | <p>HYDRAULIC CIRCUIT FOR CONTROLLING THE POSITION OF THE FRONT AND REAR FLEXI-BOARDS<br/> <b>- ONE BLUE RING</b><br/>                 Pressurizing this branch of the circuit brings the leveller up from the surface.</p>  |
|  | <p>HYDRAULIC CIRCUIT FOR CONTROLLING THE POSITION OF THE FRONT AND REAR FLEXI-BOARDS<br/> <b>- TWO BLUE RINGS</b><br/>                 Pressurizing this branch of the circuit brings the leveller down to the surface.</p>   |

HYDRAULIC DIAGRAM

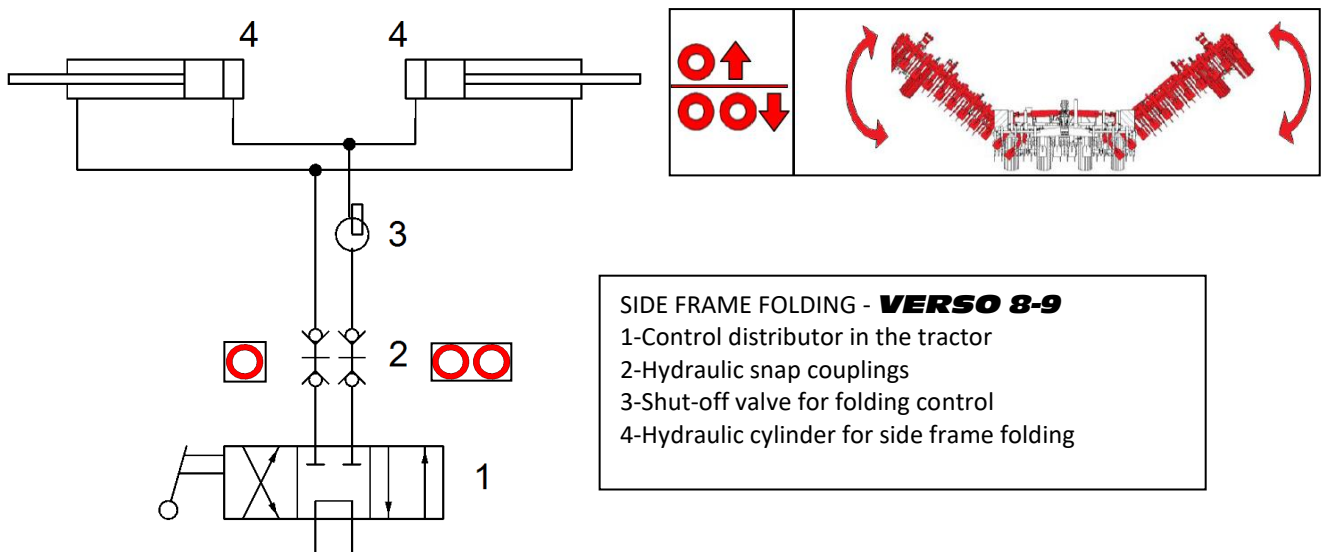



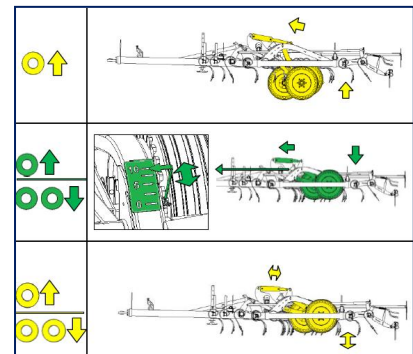
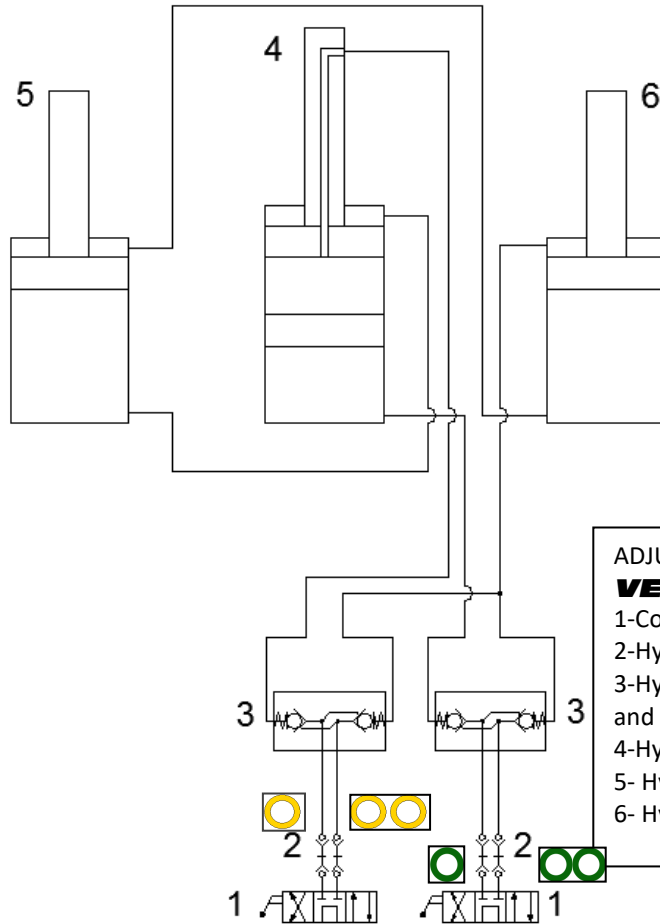

**ADJUSTING WORKING DEPTH AND AXLE CONTROL -  
VERSO 8-9**

- 1-Control distributor in the tractor
- 2-Hydraulic snap couplings
- 3-Hydraulic closing valve for depth setting cylinders and lifting machine on axles
- 4-Hydraulic cylinder for central axle control
- 5- Hydraulic cylinder for right axle control
- 6- Hydraulic cylinder for left axle control

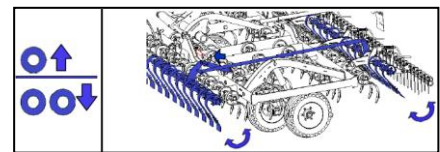
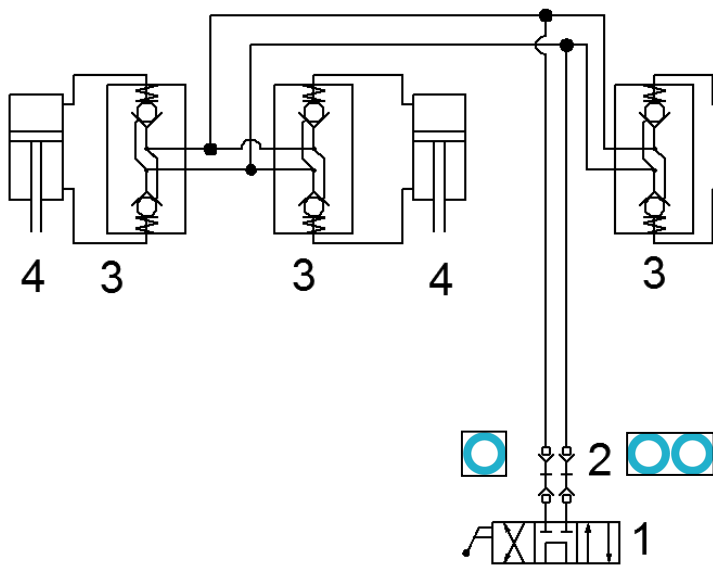

**FLEXI-BOARD CONTROL  
VERSO 6-7 + 8-9**

- 1-Control distributor in the tractor
- 2-Hydraulic snap couplings
- 3-Hydraulic closing valve for flexi-board setting cylinders
- 4-Hydraulic cylinder for flexi-board control

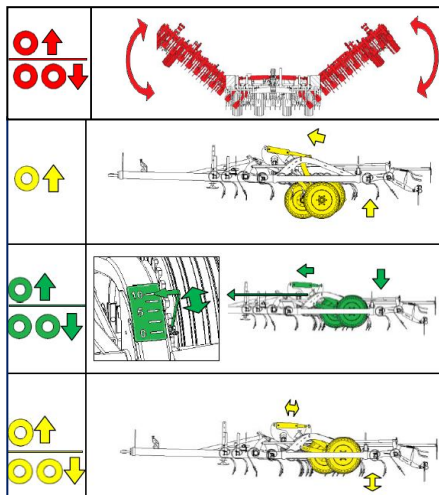
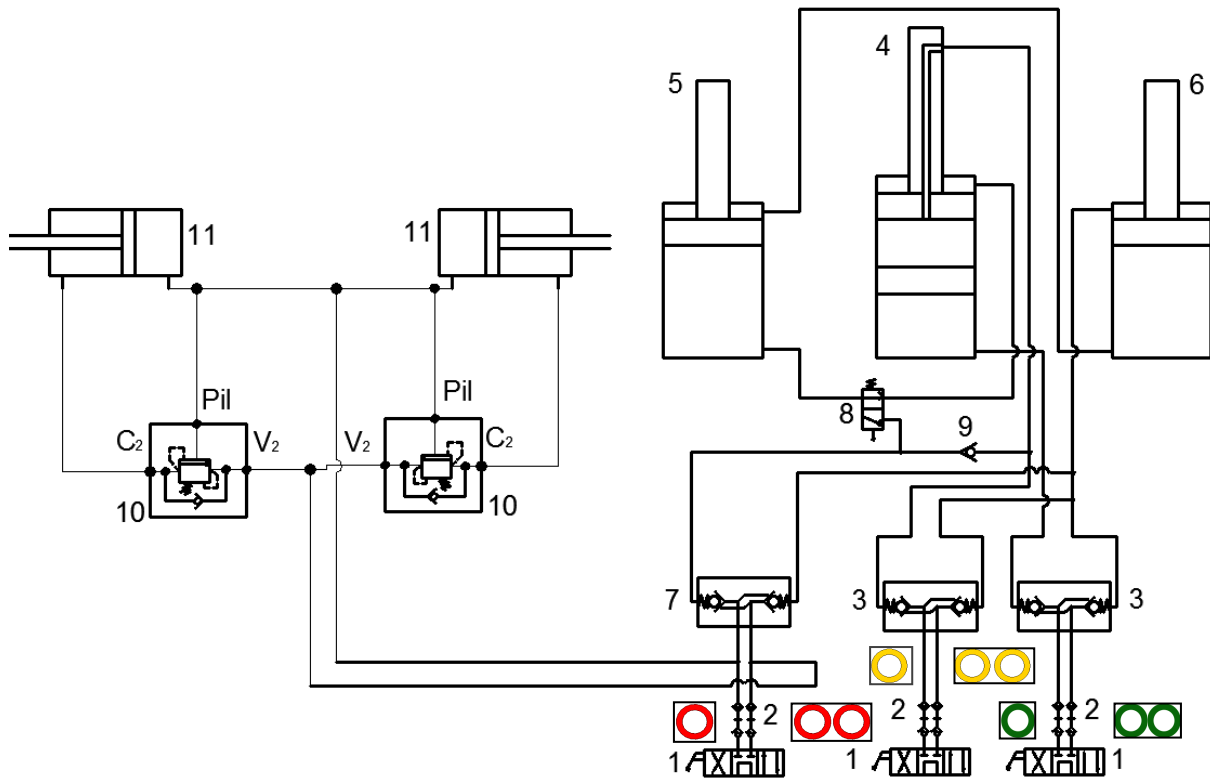

**MACHINE FOLDING + ADJUSTING WORKING DEPTH AND AXLE CONTROL**

VERSO 6-7

- 1-Control distributor in the tractor
- 2-Hydraulic snap couplings
- 3-Hydraulic closing valve for depth setting cylinders and lifting machine on axles
- 4-Hydraulic cylinder for central axle control
- 5- Hydraulic cylinder for right axle control
- 6- Hydraulic cylinder for left axle control
- 7-Hydraulic closing valve of machine folding cylinders
- 8-Hydraulic distributor for insertion of side axles after the machine is folded – mechanically controlled
- 9-Hydraulic check valve
- 10- Shut-off valve for folding control
- 11-Hydraulic cylinder for side frame folding

### 3.3 FOLDING AND UNFOLDING OF THE MACHINE

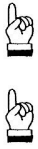

- The hydraulics for the folding and unfolding must be connected to the double-action control unit.
- The operator must ensure that during folding and unfolding of the side frames, no person or animal is within their reach (i.e. at the place of their impact) or vicinity
- Perform folding and unfolding on flat and solid surfaces or laterally to the slope with the fully open control unit.

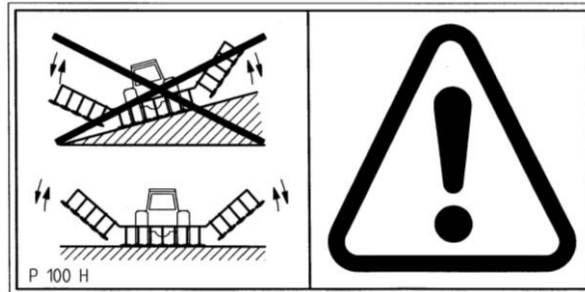

- Remove stuck soil from folding points, soil may impair function and cause damage to the mechanics.
- During folding or unfolding, check the side frames and have them continuously fold into the end position to the stoppers.

**CAUTION!!! The machine always must be lifted on the axle prior to the start of folding and when folded!**

#### 3.3.1 FOLDING THE MACHINE INTO THE TRANSPORT POSITION

- Lift the machine on the axle by pressurizing the hydraulic circuit marked with two yellow rings. Continue lifting until the piston-rod is drawn out to the end position.

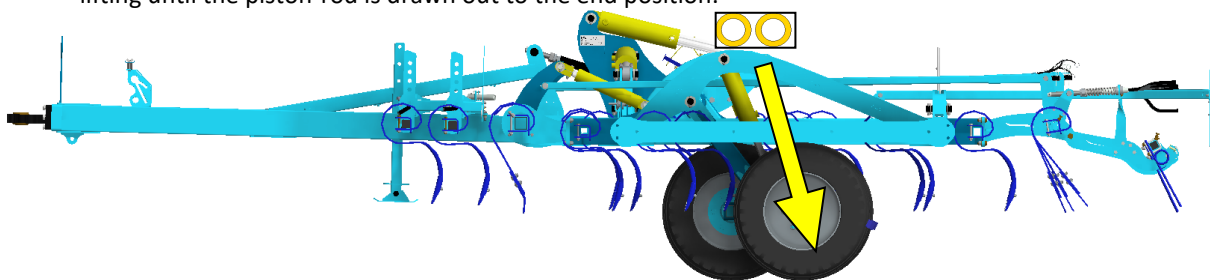

- Clean the machine from impurities.
- Fold the front Flexi-board by pressurizing the hydraulic circuit marked with one blue band.
- Pressurizing the hydraulic circuit marked with one red ring continuously folds the side frames into the transport position. The machine is factory-set so that the side frames rest on the stops of the central frame when the piston-rod is drawn out to the maximum position.
- In **VERSO 6-7** machines, continue pressurizing the hydraulic circuit marked with one red ring even when the side frames have folded, until the side axles are inserted into the transport position.

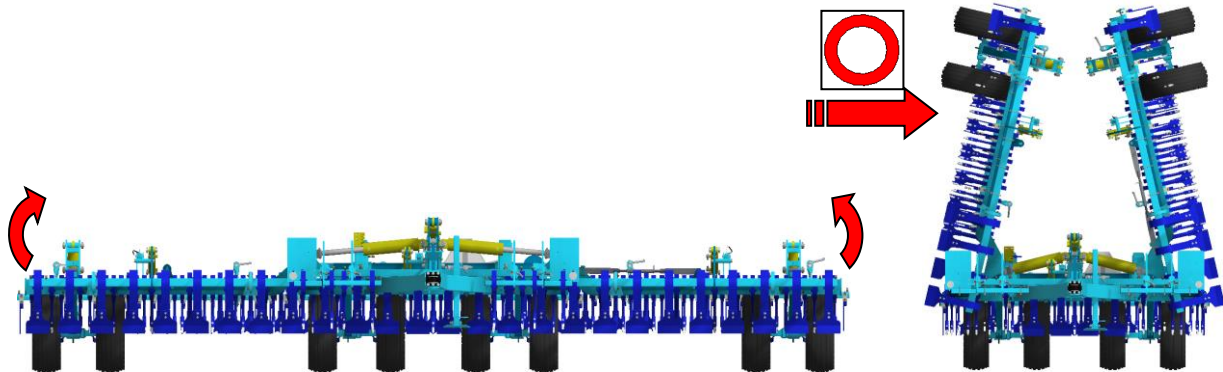

- Block or close the circuit.

- When the machine is folded into the transport position, you have to secure the side frames against unfolding by the mechanical connecting rod and locking the ball valve on the drawbar in the “closed” position.

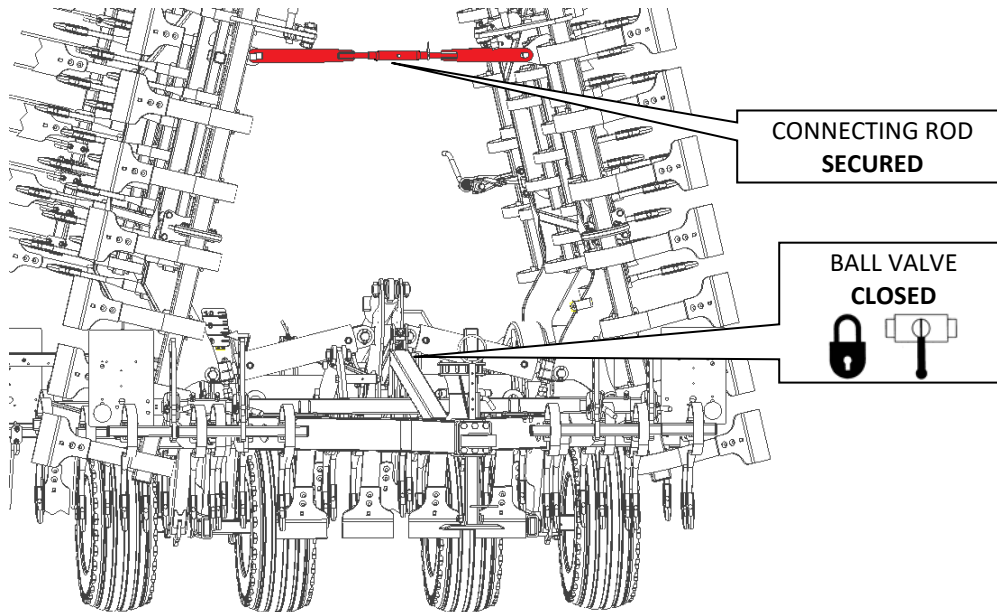

### 3.3.2 UNFOLDING THE MACHINE INTO THE WORKING POSITION

- Before starting to unfold, you must release the mechanical connecting rod and the ball valve on the drawbar into the “open” position. Failure to do so will damage the machine.

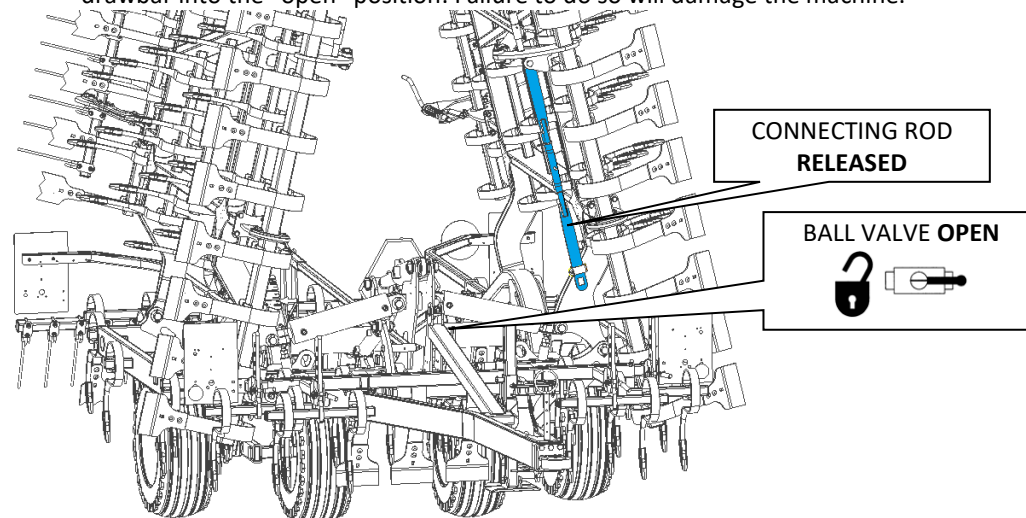

- Unfold the side frames continuously into the working position by pressurizing the hydraulic circuit marked with two red rings. Continue pressurizing the circuit until the machine is fully unfolded and the piston-rods are fully drawn out.
- In **VERSO 6-7** machines, the side axles will be ejected into the basic position.

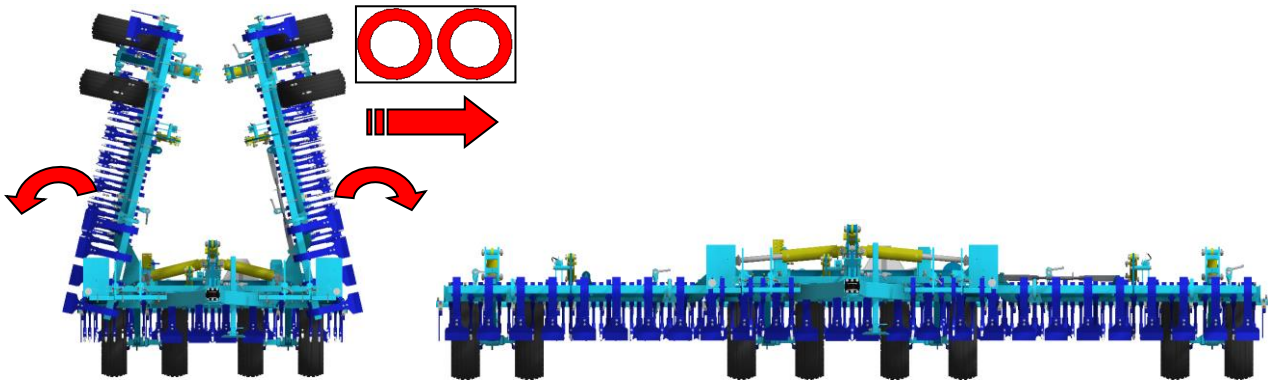

- Lower the machine down to the ground by pressurizing the hydraulic circuit marked with one yellow ring. Continue until the machine is in the working position.

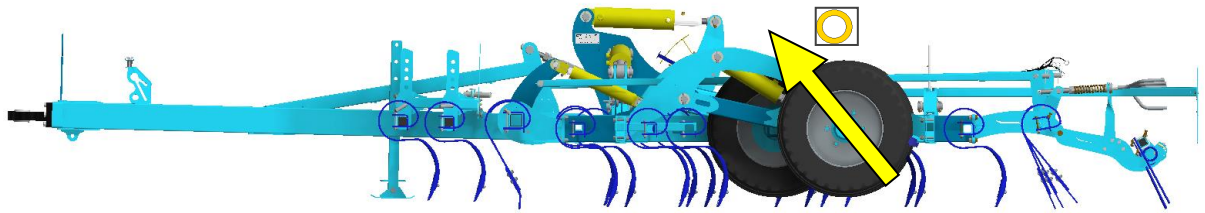

- Block or close the circuits.

## 4. MACHINE TRANSPORT ON ROADS

### Transport Position of **VERSO**

- Connect the machine to the bottom hitch of the tractor or using a two-point hitch (TPS 3).
- Connect the brakes of the machine (if supplied) to the tractor using the brake head – release the brakes before lifting the machine on the axle.
- Lift the machine on the axle.
- Fold the side frames into the transportation position.
- Always secure the side frames using the safety rod!
- The front Flexi-boards must be completely drawn in.
- Track cultivators must not lap over the front lights.
- The machine must be equipped with removable shields with marking of contours, functional lighting, and the board of the rear marking for slow vehicles (according to ECE No. 69).
- The lighting must be activated during travelling on roads.
- The tractor must be equipped with a special light device of an orange colour, which must be activated during travelling on roads.
- The maximum transport speed during travelling on roads is **20 kph (12,4 mph)**.



### Ban of transport with decreased visibility!

- Bring the machine into the transport position.
- The operator is obliged to pay increased attention during transport on roads, due to the transport dimensions of the machine.
- The operator must observe the valid regulations for transport on roads (laws, decrees) after connecting the machine to the tractor, for reason of a change of the axle load. The driving properties of the set also change depending on the terrain nature, adapt the manner of driving to these conditions.
- The operator is obliged to present the machine certificate of roadworthiness as needed, according to the valid regulations for road traffic (decree, law) (only in the Czech Republic).
- The operator is obliged to secure sufficient outlook during reversing from his position of the tractor driver. In case of insufficient outlook, the operator is obliged to call a competent and informed person.
- The operator must fold the side frames for transport and secure them against unwanted unfolding by disconnecting the hydraulic circuit of the machine and the tractor.
- The operator must secure the arms of the rear TPS of the tractor in the transport position during road transport, i.e. prevent unexpected arm drop using the hydraulic arm control lever. At the same time, the arms of the rear TPS of the tractor must be secured against side swinging.
- During machine transport on roads, the operator must observe the valid laws and decrees that deal with this topic, and which specify the relationships of the tractor axle load depending on transport speed.



The **VERSO 9** machine exceeds the transport dimensions for driving on roads (height above 4m) and therefore this machine is not approved for driving on roads.



When extending **VERSO 8** to 9m, the certificate of roadworthiness issued for **VERSO 8** is no longer valid due to the transportation height increased above the permitted value. Transportation on public roads with the machine extended to 9m is not permitted.



### Checking the nuts on the transport axle

- Use the plastic arrow “Check Point” to check for loose nuts. It promptly shows the condition of the nuts, whether they are loose or not.
- Always check the Check Points before driving.
- When the arrows are not facing one another, the nuts have to be tightened to the required torque and the Check Point arrows have to point against one another as shown in the green picture.

Torque for the axle nuts:

M18x1,5 - 265Nm

M20x1,5 - 343Nm

M22x1,5 - 440Nm

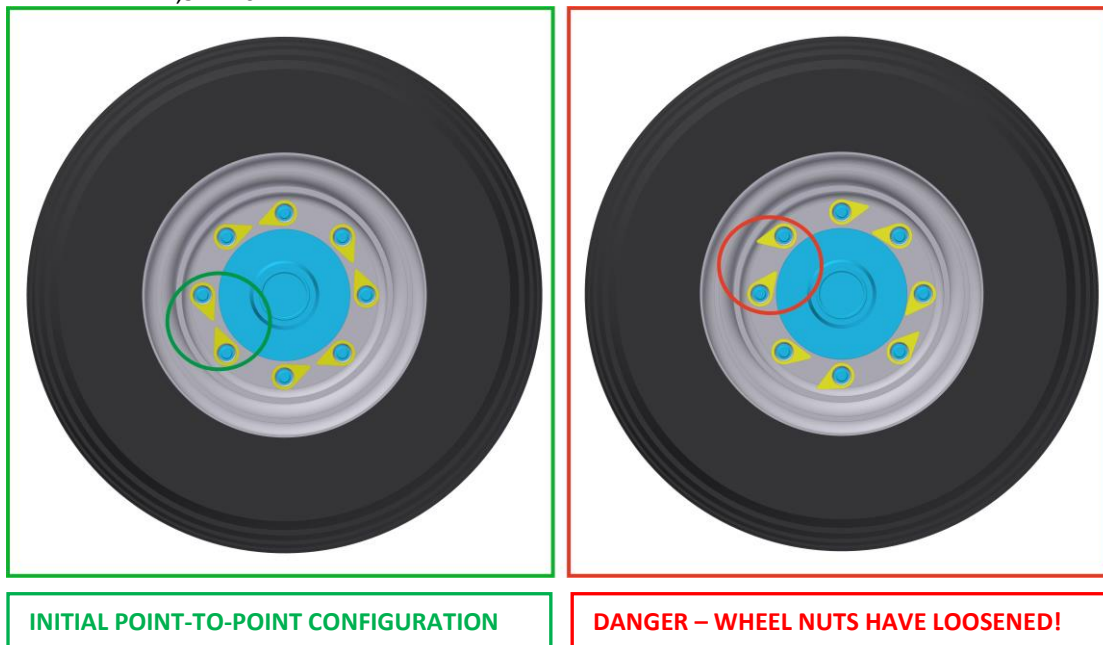

### 4.1 SHARP MACHINE PROJECTION



- The machine contains sharp structural projections
- **It is prohibited to operate and transport the machine on roads when visibility is reduced!!** - Persons or objects, or other road traffic participants could get caught.
- **The machine operator must be extra cautious when driving on roads and consider the width of the machine and safe distance from persons, vehicles and objects, or other road traffic participants!!**

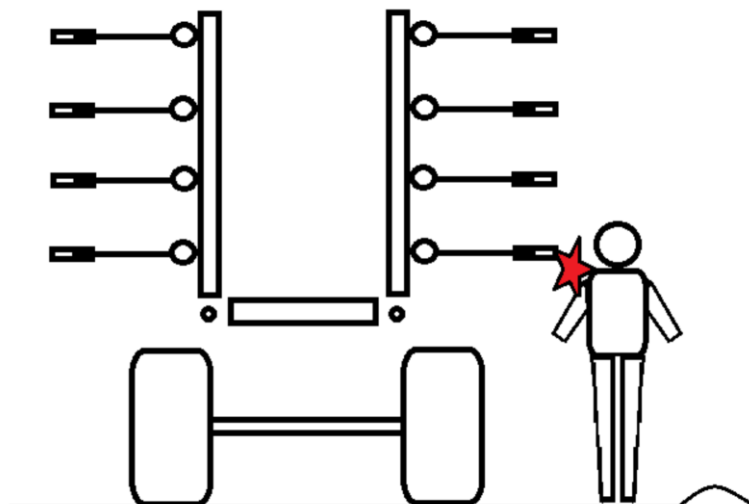

## 5. MACHINE ADJUSTMENT

Fig.5 – Machine adjustment

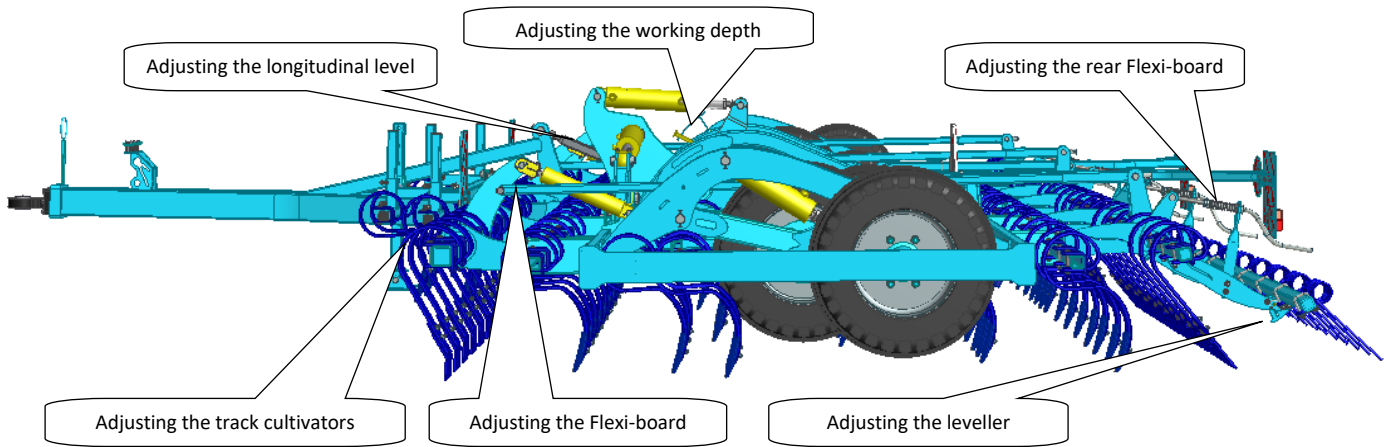

### 5.1 ADJUSTING THE WORKING DEPTH OF THE MACHINE

#### 5.1.1 ADJUSTING THE DEPTH INDICATOR

- The indicator is correctly set when it shows Position 0 from the driver's position in the tractor and the working parts are touching the ground.
- Always adjust the indicator on a flat and firm surface by changing the position of the stop screw.

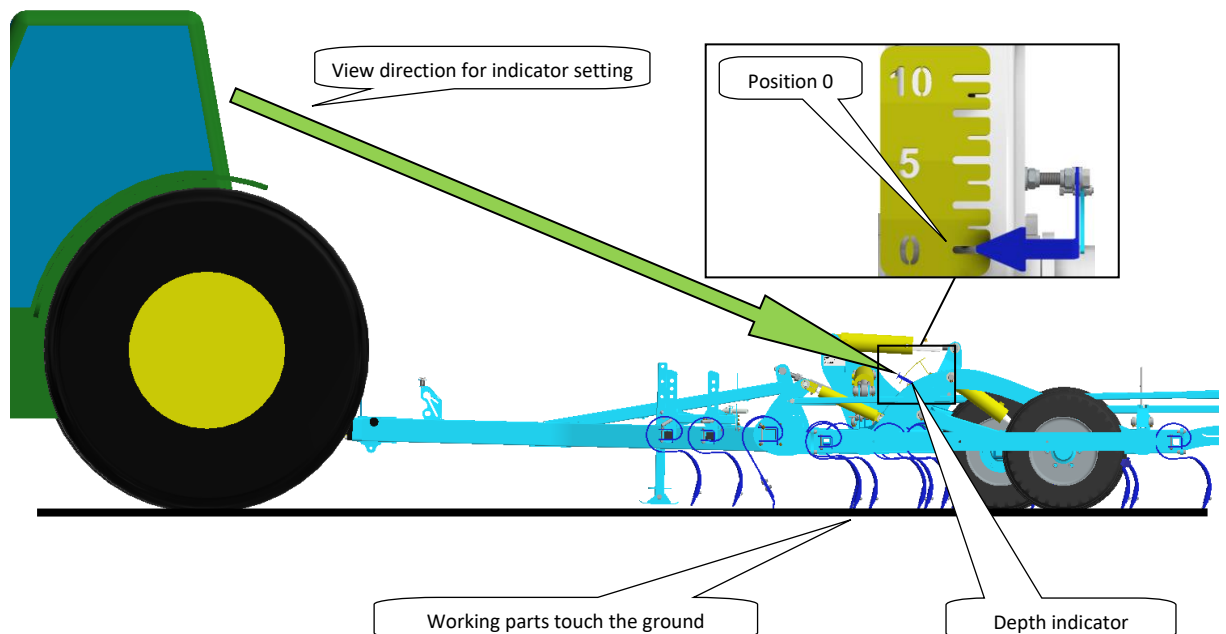

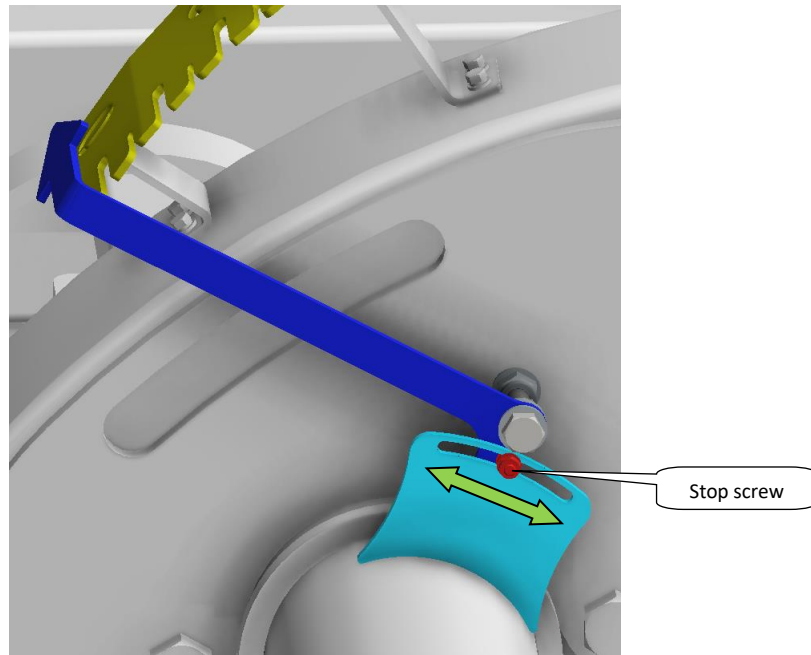

### 5.1.2 ADJUSTING THE WORKING DEPTH

- The working depth is adjusted hydraulically by the green circuit when the machine is unfolded.
- Using the hydraulic circuit marked with a single yellow ring, place the machine into the working position.

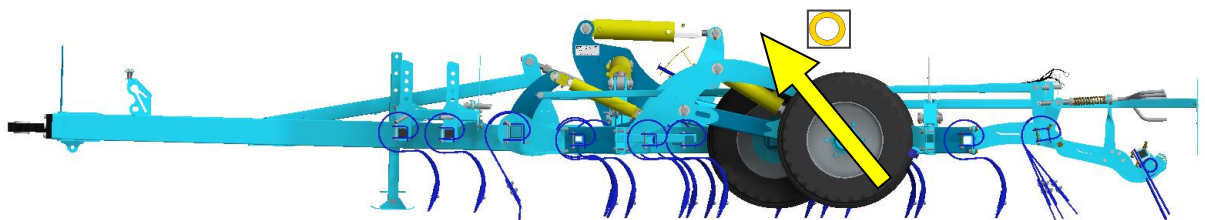

- Using the green hydraulic circuit, set the required working depth.

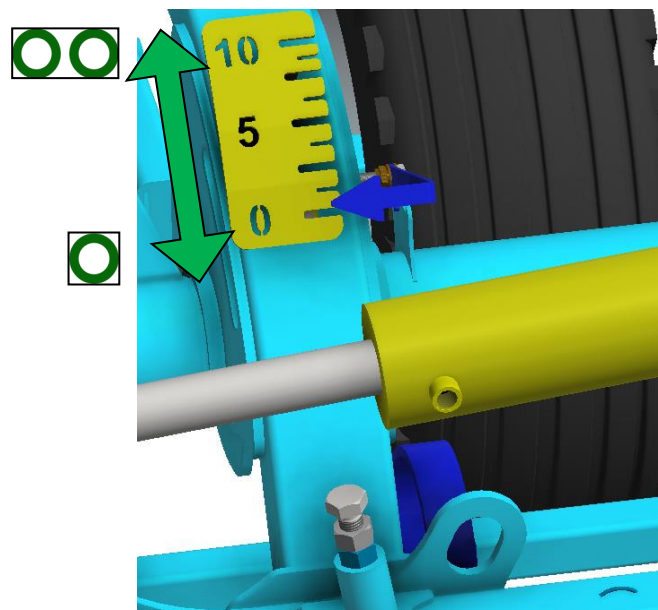

- To maintain the working depth, do not move the green circuit. Only use the yellow hydraulic circuit to lift the machine at headland.

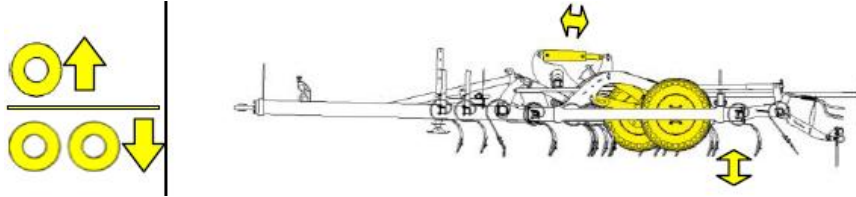

## 5.2 ADJUSTING THE LONGITUNIDAL LEVEL OF THE MACHINE

- In relation to the used pulling vehicle, the longitudinal level of the machine must be adjusted so that all the shares are at the same height.
- When adjusting, observe generally valid legal regulations.
- The set depth of all working parts is only maintained when the longitudinal level of the machine is correctly adjusted.
- Use the adjustable rod and wrench size 46.

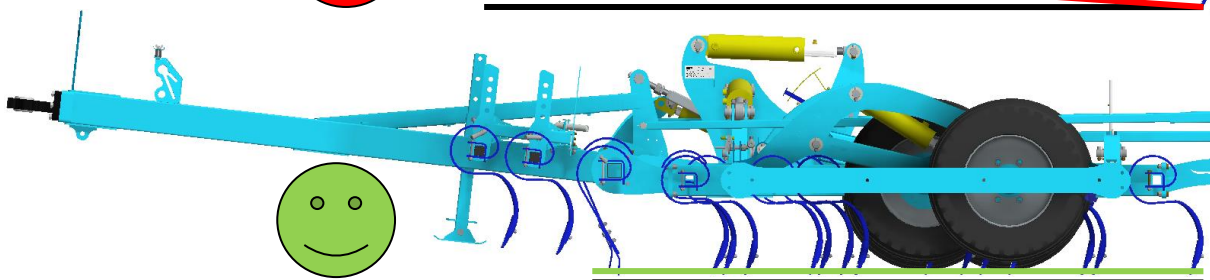
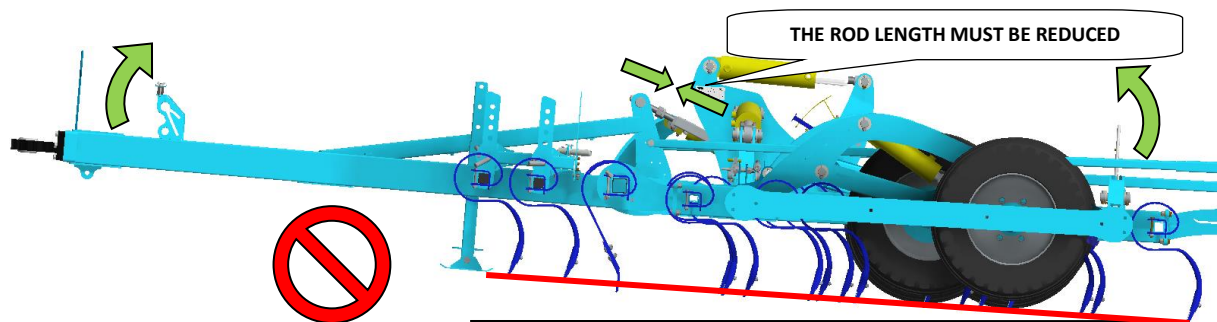
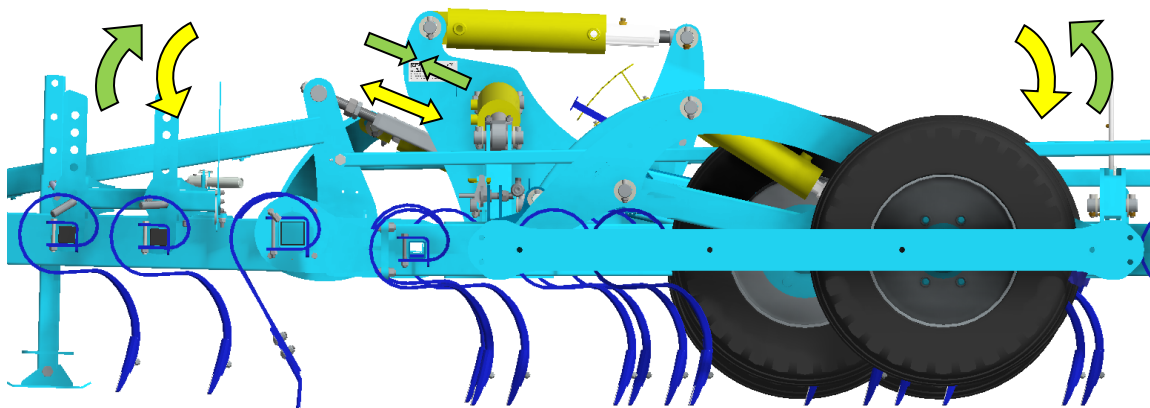
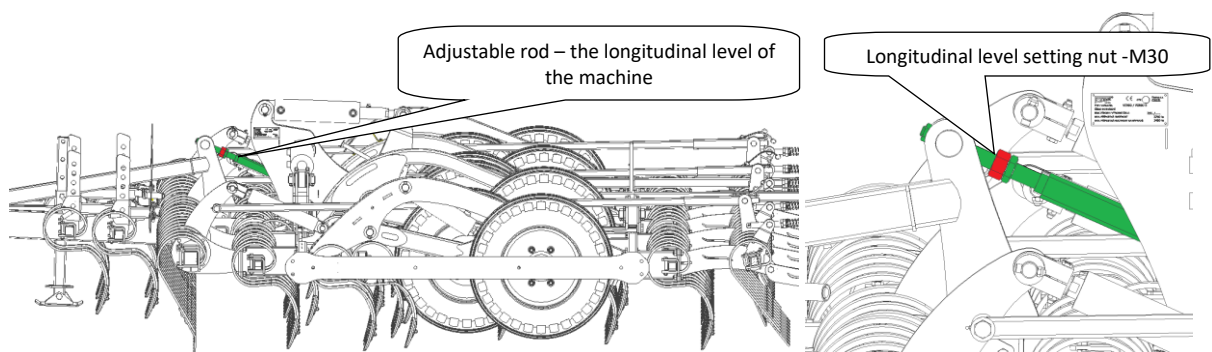

### 5.3 ADJUSTING THE TRACK CULTIVATOR

- Correct position of the track cultivator affects the resulting quality of processing.
- The tractor track cultivator position can be adjusted either by height or length, as needed.
- When adjusting the track cultivator positions, always observe generally valid labour safety regulations.
- The track cultivators are located on the beams of the pulling fork. The cultivator can be moved on the beam so that it loosens the compacted tractor wheel tracks.
- The depth of the cultivator is set by removing the pin and moving the cultivator in the holder. Before you set the depth of the cultivators, place the machine in the position when the cultivators are not loaded.

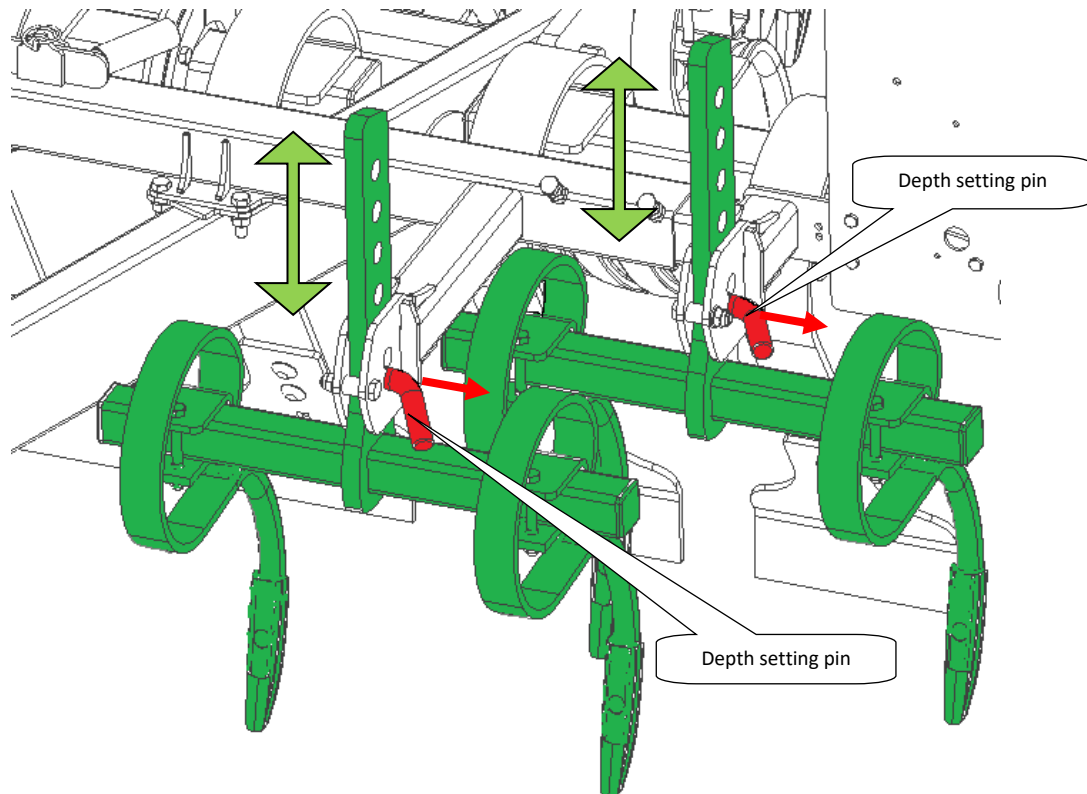

- Lengthwise setting of the cultivators is performed by releasing the nuts of the screws and moving the cultivators along the beam into the position behind the tractor wheels so that they loosen the compacted tractor tracks.
- The edge cultivators are located on the adjustable beam that can be extended into the required position by loosening the screws.



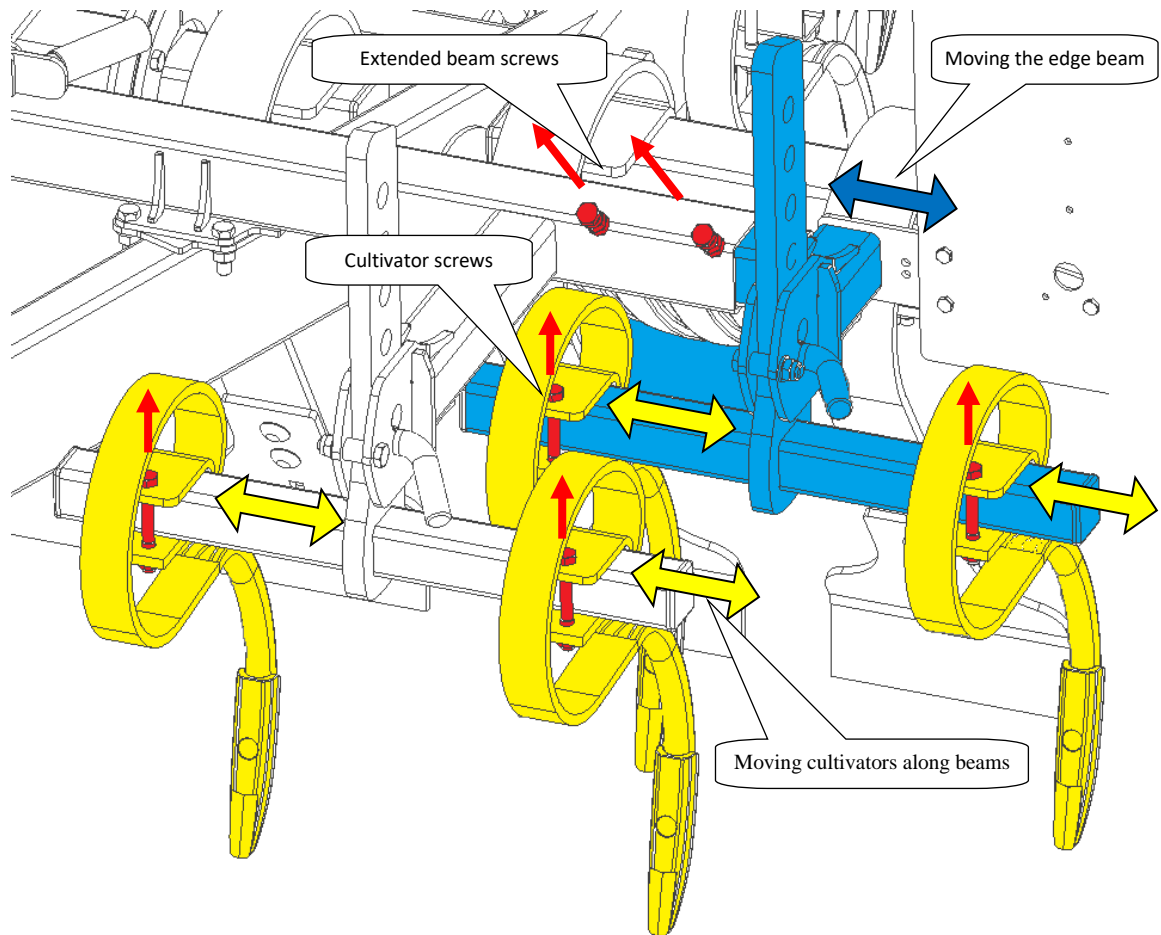

## 5.4 ADJUSTING THE FLEXI-BOARD

- Correct position of the Flexi-boards affects the resulting quality of processing.
- When adjusting, always observe generally valid safety regulations.
- Adjust the Flexi-boards according to the current conditions.
- Flexi-boards are adjusted hydraulically by the blue circuit. This circuit controls the front and rear row concurrently.
- The rear row moves more slowly than the front row during adjustment; the ratio is approx. 2:3.
- The depth and angle against the land are both changed during the setting.
- The position must be adjusted according to the set working depth.
- The front Flexi-boards must be sufficiently low so that they can level unevenness and crush soil clods, but soil must not be accumulated in front of the boards.

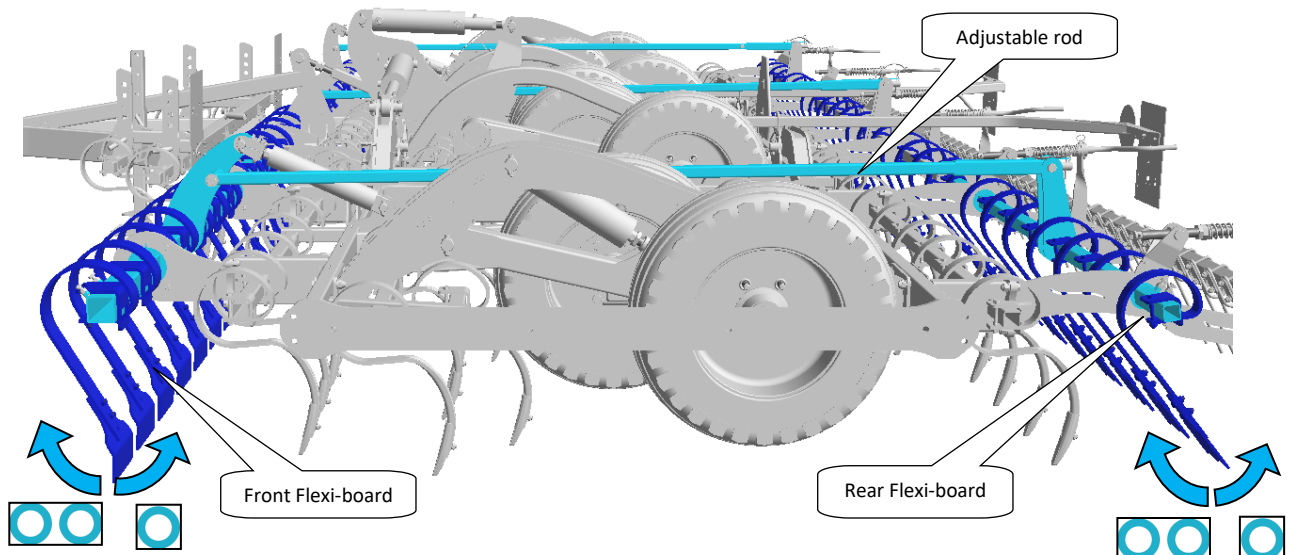



- The rear row can be adjusted independently of the front row.
- When adjusting the rear row, use the handle located at the rear target discs (it is recommended to have the hydraulic cylinders drawn in).
- Set the rear Flexi-boards so that they level the soil after the main working parts without accumulating soil in front of them.

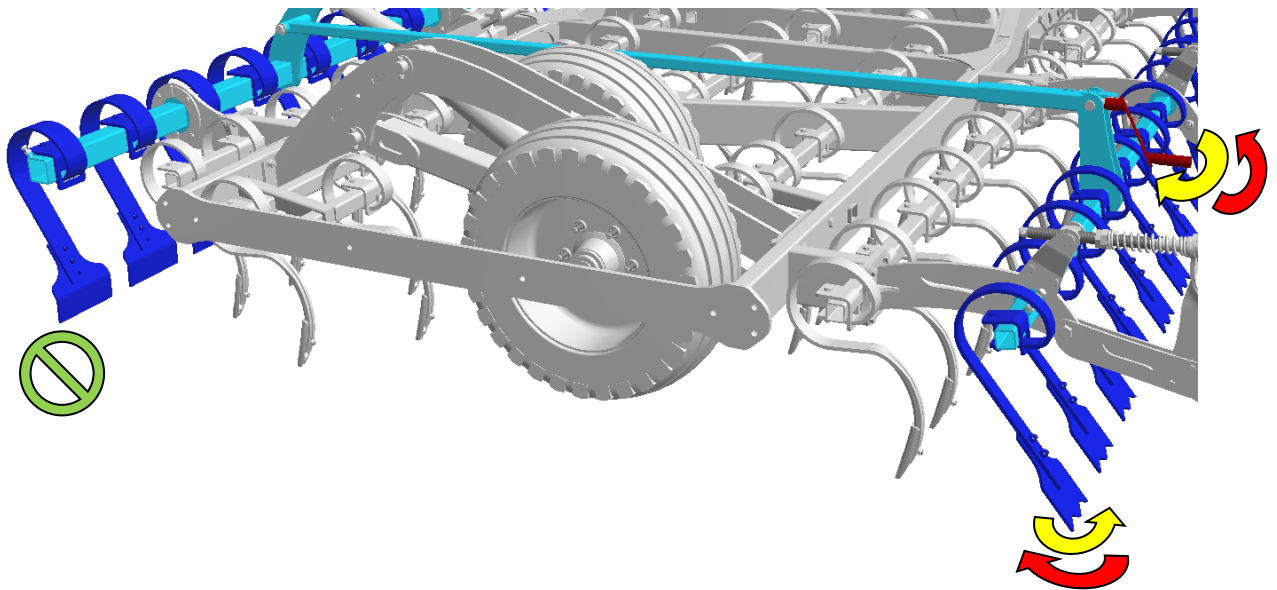
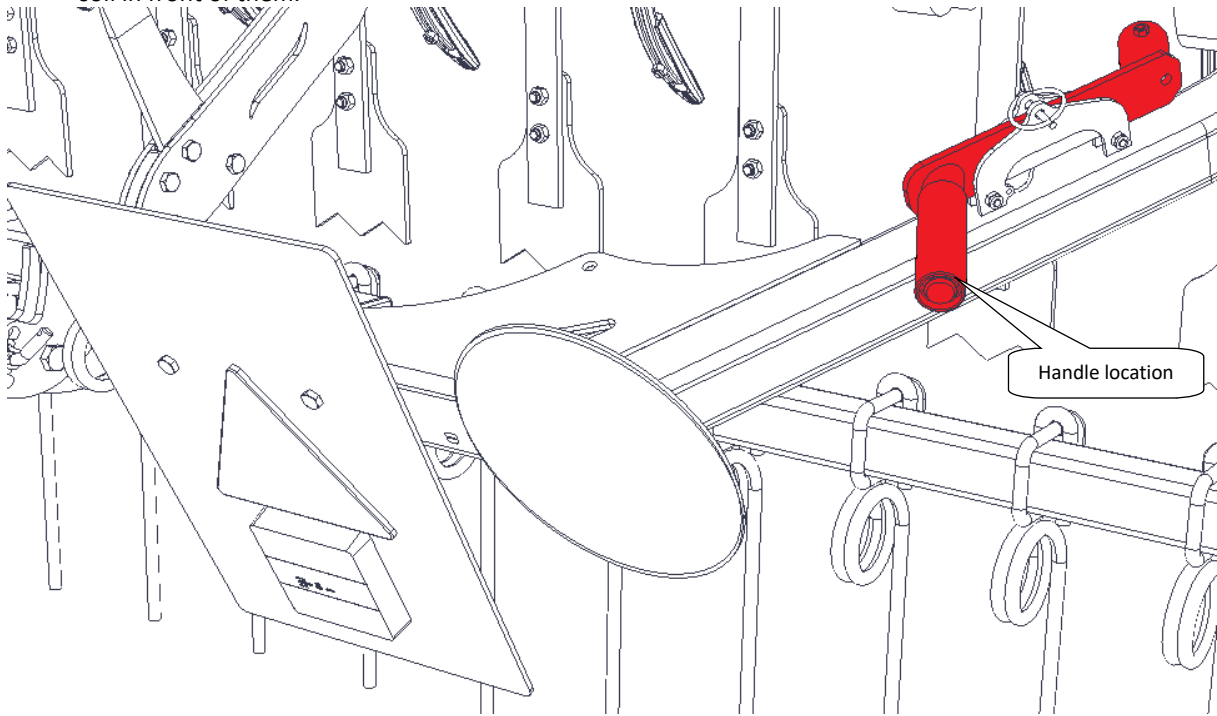

## 5.5 ADJUSTMENT THE LEVELLER

- Correct setting of the leveller affects the resulting quality of processing.
- When adjusting, always observe generally valid safety regulations.
- Set the leveller so that it levels soil after it has been processed by the other parts of the machine.
- The angle of the leveller is adjusted by removing the pins and turning the beam into the required position.
- The height of the leveller is adjusted by the handle.
- By preloading the spring, it is possible to adjust the down-pressure of the leveller (releasing or tightening nuts with head 41)

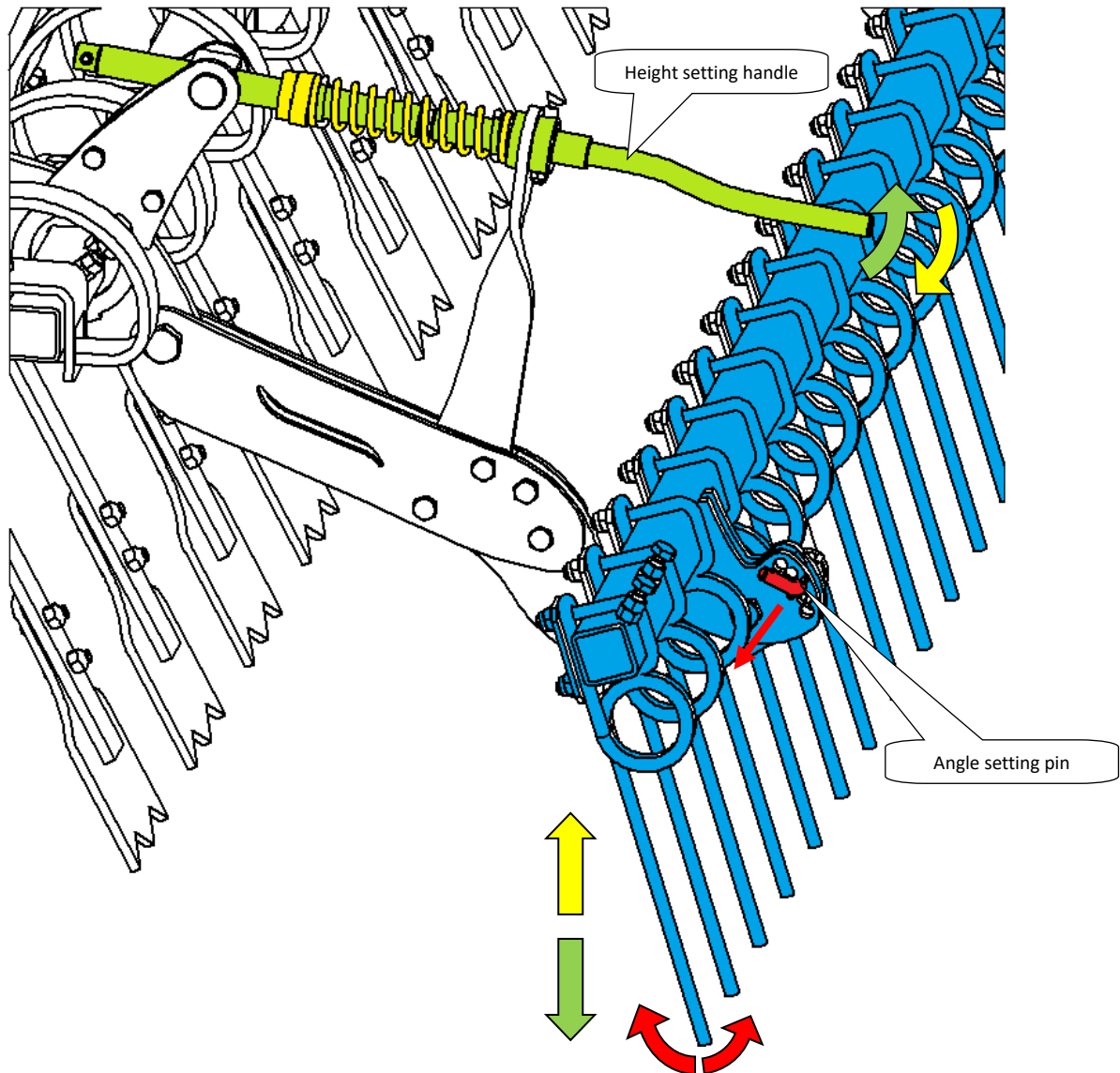

## 6. MACHINE MAINTENANCE AND REPAIRS



**Observe the safety instructions for treatment and maintenance.**

- If it is necessary to weld during the repair and have the machine connected to the tractor, it must have disconnected supply cables from the alternator and the accumulator.
- Check the tightening of all screw and other assembly connections at the machine before every use of the machine, furthermore continuously as needed.
- Continuously check the wear of the working bodies of the machine, possibly replace these worn working bodies with new ones.
- Adjustment, cleaning, and lubrication of the machine may only be performed with the machine at rest (i.e. the machine is standing and not working).
- When working on a lifted machine, use suitable support equipment supported at marked points or at points suitable for that.
- During adjustment, cleaning, maintenance, and repair of the machine, you must secure those parts of the machine that could endanger the operator by falling or another movement.
- For catching the machine during handling using lifting equipment, use only the places marked with self-adhesive labels with the chain sign "  ".
- Upon a failure or damage of the machine, immediately turn off the tractor's engine and secure against restarting, secure the machine against movement ⇒ only then you can remove the failure.
- During repairs of the machine, use exclusively the genuine spare parts, suitable tools and protective equipment.
- Regularly check the prescribed pressure in the machine tyres and the condition of the tyres. Perform possible repairs of the tyres in an expert workshop.
- Keep the machine clean.



**Do not clean hydraulic cylinders and bearings with a high-pressure cleaner or direct water stream. The seals and bearings are not watertight at high pressure.**

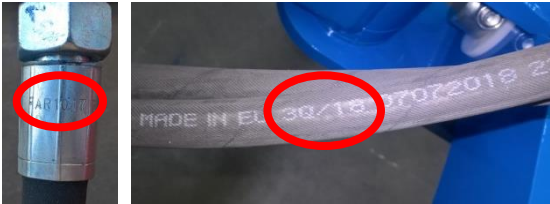

|   |   |  |  |   |         |
|---|---|--|--|---|---------|
| <p><b>Hydraulic hoses – replacement:</b></p> <ul style="list-style-type: none"> <li>• Damaged external casing of the hose (mechanically or blistered)</li> <li>• Fluid seepage (especially the end piece)</li> <li>• Bumps or blisters on the hose</li> <li>• Deformed or corroded end piece</li> <li>• Loose end piece – the hose spins</li> </ul> | X |  |  | X |         |
| <p>Hydraulic hoses - replacement:</p> <ul style="list-style-type: none"> <li>• Expired service life of the hose</li> </ul>   |   |  |  |   | 6 years |
| <p><b>!!! PREVENTION means removing the problem according to the plan, outside the season, without stress and comfortably before a secondary problem, an accident or a health hazard arises.</b></p>  |   |  |  |   |         |

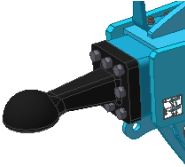
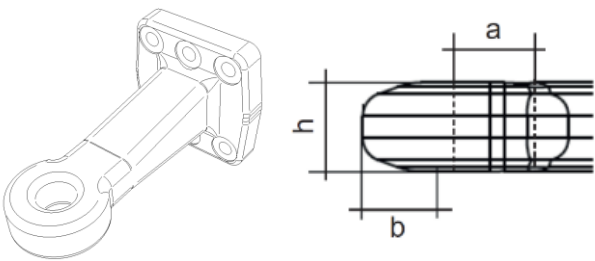
| <b>MAINTENANCE PLAN</b>   |                |             |               |              |               |   |   |  |  |
|---|----------------|-------------|---------------|--------------|---------------|---|---|--|--|
| Perform the planned maintenance according to the instructions:  |                |             |               |              |               |   |   |  |  |
| Maintenance Task  | Daily (season) | Once a week | Before season | After season | Time interval |   |   |  |  |
| <b>Bolt connections</b>   |                |             |               |              |               |   |   |  |  |
| <p><b>Visual</b> inspection of bolt and hydraulic joints, tighten any loose joints using a corresponding torque (see the torque chart)</p>  | X              |             |               | X            |               |   |   |  |  |
| <p><b>Towing lug – check, tighten if needed</b></p> <table border="1" data-bbox="204 1527 507 1608"> <tr> <td>M16 - 10.9.</td> <td>300 Nm</td> </tr> <tr> <td>M20 - 10.9.</td> <td>560 Nm</td> </tr> </table>  | M16 - 10.9.    | 300 Nm      | M20 - 10.9.   | 560 Nm       |               | X | X |  |  |
| M16 - 10.9.   | 300 Nm         |             |               |              |               |   |   |  |  |
| M20 - 10.9.   | 560 Nm         |             |               |              |               |   |   |  |  |
| <p><b>Towing lug without joint – check for wear</b><br/>Replace the part when the deviation of one of the dimensions is larger than the defined limit value.</p>   |                | X           | X             |              |               |   |   |  |  |

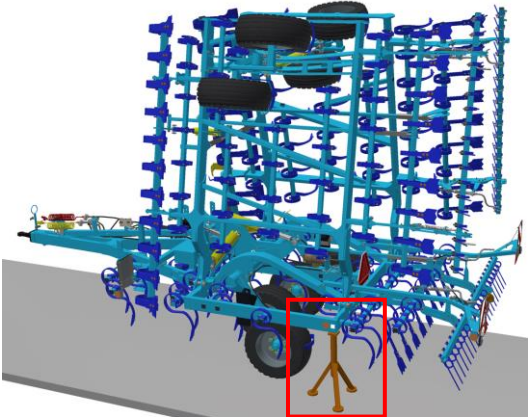
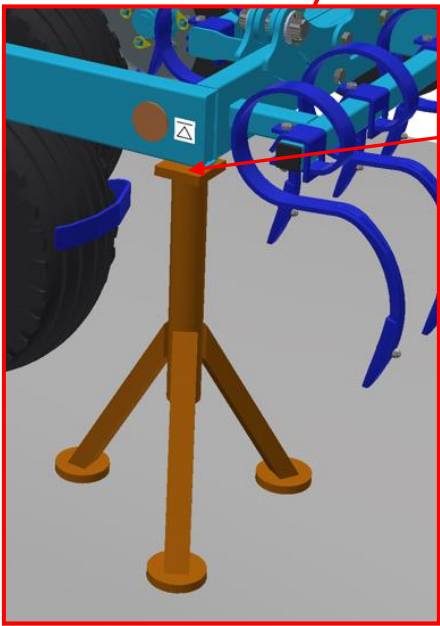

| Designation   | Nominal dimension (mm) | Wear dimension (mm) |            |        |            |        |            |        |   |   |  |  |  |
|---|------------------------|---------------------|------------|--------|------------|--------|------------|--------|---|---|--|--|--|
| <u>Eye C50</u>  |                        |                     |            |        |            |        |            |        |   |   |  |  |  |
| ∅ eye a   | 51                     | 53                  |            |        |            |        |            |        |   |   |  |  |  |
| ∅ eye a   | 71                     | 73                  |            |        |            |        |            |        |   |   |  |  |  |
| Width of ring b   | 25,5                   | 23,0                |            |        |            |        |            |        |   |   |  |  |  |
| Height of ring h  | 54,0                   | 51,5                |            |        |            |        |            |        |   |   |  |  |  |
| <u>Eye C40</u>  |                        |                     |            |        |            |        |            |        |   |   |  |  |  |
| ∅ eye a   | 42                     | 43,5                |            |        |            |        |            |        |   |   |  |  |  |
| Width of ring b   | 28,8                   | 28,1                |            |        |            |        |            |        |   |   |  |  |  |
| Height of ring h  | 38,0                   | 35,5                |            |        |            |        |            |        |   |   |  |  |  |
| <b>Wheels – tighten all wheel nuts.</b> <ul style="list-style-type: none"> <li>• <b>First time: after 10 hours of operation</b></li> <li>• <b>Wheel replacement: after 10 hours of operation</b></li> </ul> <table border="1" style="margin-left: 20px;"> <tr> <td>M 18 x 1,5</td> <td>300 Nm</td> </tr> <tr> <td>M 20 x 1,5</td> <td>400 Nm</td> </tr> <tr> <td>M 22 x 1,5</td> <td>500 Nm</td> </tr> </table> |                        |                     | M 18 x 1,5 | 300 Nm | M 20 x 1,5 | 400 Nm | M 22 x 1,5 | 500 Nm | X | X |  |  |  |
| M 18 x 1,5  | 300 Nm                 |                     |            |        |            |        |            |        |   |   |  |  |  |
| M 20 x 1,5  | 400 Nm                 |                     |            |        |            |        |            |        |   |   |  |  |  |
| M 22 x 1,5  | 500 Nm                 |                     |            |        |            |        |            |        |   |   |  |  |  |
| <b>Maintenance of brakes and axle</b>   |                        |                     |            |        |            |        |            |        |   |   |  |  |  |
| Support the machine in the support point before the brake and axle maintenance.   |                        |                     |            |        |            |        |            |        |   |   |  |  |  |
| <br>  |                        |                     |            |        |            |        |            |        |   |   |  |  |  |

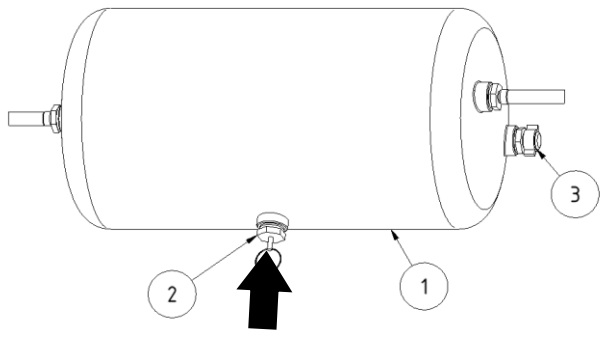

|   |   |  |   |   |  |
|---|---|--|---|---|--|
| <p><b>Lifting jack support point</b> – (1)end frame beam</p> <p>Work connected with the repair, change or regeneration of axle and brakes elements should be entrusted to specialist establishments, having the appropriate technology and qualifications for this type of work.</p> <p>The responsibilities of the user are limited to:</p> <div style="border: 1px solid black; padding: 5px; display: flex; align-items: center;">  <p><b>DANGER</b><br/>Do NOT use the machine when braking system is unreliable.</p> </div>   |   |  |   |   |  |
| <p>Brake system</p>   |   |  |   |   |  |
| <p><b>Brake line and hoses</b> – check the function, tightness, mounting and clamping, or breaking</p>  | X |  | X | X |  |
| <p><b>Quick couplers</b>– cleaning and maintaining</p> <p>In the event of damage to cover or seal, change these elements for new reliable elements.</p> <p>Contact of pneumatic connector seals with oils, grease, petrol etc. may cause damage and accelerate ageing process.</p> <p>If the machine is unhitched from the tractor, connectors should be protected by caps or placed in their designated sockets. Before the winter period it is recommended to preserve the seal with special preparations (e.g. silicon grease for rubber elements).</p> <p>Each time before hitching the machine, inspect technical condition and cleanness of connectors and sockets in tractor. If necessary, clean or repair tractor sockets.</p>   |   |  |   |   |  |
| <p><b>Brake cylinder</b> – stroke check, check the arm angle when braking</p> <p><u>Description:</u></p> <p>Considerable wear of brake shoe linings results in increased brake cylinder piston stroke and worse braking efficiency - Correct brake cylinder piston stroke should be within the range of 25 – 45 mm.</p> <p>During braking, the brake cylinder piston stroke should be within the specified operating range. Braking force decreases when the operating angle of the brake cylinder piston (5) in relation to the expander arm (1) is wrong – figure. In order to obtain the optimum mechanical operating angle, the cylinder piston fork (5) must be installed on the expander arm (3) in such a manner as to ensure that the operating angle at full braking is about 90°- figure.</p> | X |  |   |   |  |

|   |   |  |   |   |  |
|---|---|--|---|---|--|
| <p>(1) Brake cylinder piston<br/>         (2) Brake cylinder membrane<br/>         (3) Expander arm<br/>         (4) Cylinder fork<br/>         (5) Position of fork pin<br/>         (A) Mark of brake cylinder<br/>         (B) Position of arm at brake release position<br/>         (C) Position of arm at full braking position</p> <p>Control:</p> <p>The inspection of the brake operation involves measuring the extension length of each brake cylinder piston while braking at parking. If the brake cylinder piston stroke exceeds the maximum value (45 mm), the braking system should be adjusted.</p>  |   |  |   |   |  |
| <p><b>Brake components</b> – check the function, tightness, mounting</p> <p>Description checking air tightness:</p> <ul style="list-style-type: none"> <li>• Connect the machine to tractor.</li> <li>• Immobilise tractor and machine with parking brake, place the wheel chocks under the machine wheels.</li> <li>• Start tractor in order to supplement air in the machine braking system tank.</li> <li>• In double conduit systems air pressure should amount to 6,5 - 8 bar.</li> <li>• Turn off tractor engine.</li> <li>• Check system components by releasing brake pedal in tractor.</li> <li>• Give particular attention to conduit connections and brake cylinders.</li> <li>• Repeat the system check with depressed tractor brake pedal.             <ul style="list-style-type: none"> <li>- The help of a second person is required.</li> </ul> </li> </ul> <p>In the event of the appearance of leaks, compressed air will escape at the places of damage, with a characteristic hiss. Lack of system tightness may be also detected by</p> | X |  | X | X |  |

|   |  |   |  |   |  |
|---|--|---|--|---|--|
| <p>covering checked elements with washing fluid or other foaming preparations, which will not react aggressively with system components. Damaged components should be replaced or repaired. If leaks appear at connections then tighten the connections. If air continues to escape, replace connection components or seals.</p> <p><b>Visual inspection of the system</b><br/>                 During tightness inspection attention should additionally be given to technical condition and degree of leanness of the system components. Contact of pneumatic conduit seals etc. with oil, grease, petrol etc. may cause damage and accelerate the ageing process. Bent, permanently deformed, cut or worn conduits should be replaced.</p> |  |   |  |   |  |
| <p><b>Air tank – drainage by drain valve</b></p>  <p><b>Draining water from air tank - (1) air tank, (2) drain valve</b><br/>                 Required maintenance activities:</p> <ul style="list-style-type: none"> <li>• Open out drain valve (2) located in the lower part of tank (1).</li> <li>• The compressed air in the tank causes the removal of water to the exterior.</li> <li>• Released valve stem should automatically close and stop flow of air from the tank.</li> <li>• If the valve stem resists returning to its position, then the whole drain valve must be unscrewed and cleaned or replaced (if it is damaged)</li> </ul>         |  | X |  | X |  |

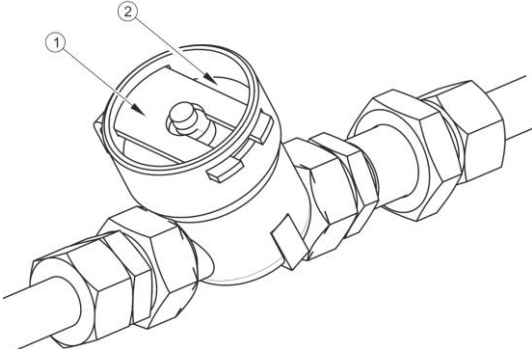
|  |  |  |   |   |  |
|--|--|--|---|---|--|
| <p><b>Draining valve</b> – check the function, clean and replace sealing</p> <div style="border: 1px solid black; padding: 5px; margin-bottom: 10px;">  <p><b>DANGER</b><br/>Release air from the air tank before dismantling drain valve.</p> </div> <p>Required maintenance activities:</p> <ul style="list-style-type: none"> <li>• Reduce pressure in air tank.</li> <li>• Reduction of pressure in tank is achieved by tilting the drain valve stem.</li> <li>• Unscrew valve.</li> <li>• Clean valve, blow with compressed air.</li> <li>• Change seal.</li> <li>• Screw in valve, fill tank with air and check tank tightness.</li> </ul>  |  |  | X | X |  |
| <p><b>Pipe filter</b> – clean</p> <div style="border: 1px solid black; padding: 5px; margin-bottom: 10px;">  <p><b>DANGER</b><br/>Before proceeding to dismantle filter, reduce pressure in supply conduit. While dismantling the slide lock, hold the cover with the other hand. Stand away from filter cover vertical direction.</p> </div> <p>Depending on the machine working conditions, but not less than once in three months, take out and clean air filter elements, which are located in pneumatic system connection conduits. Filter elements are used many times and are not subject to change unless they are mechanically damaged.</p>  <p><b>Air filter</b> - (1) securing slide lock, (2) air filter cover</p> |  |  | X | X |  |
| <p><b>Brake lining</b> – check the condition of the brake lining, min. thickness of 3mm</p>  |  |  |   | X |  |

| Wheels/axle                  |         |  |                            |   |  |  |
|------------------------------|---------|--|----------------------------|---|--|--|
| Weights and tyres            |         |  |                            |   |  |  |
| Tyre combination<br><i>n</i> | Axle n° | Tyre dimension incl<br>load capacity index &<br>speed category<br>symbol | Tyre pressure<br>[kPa] (*) | Tyre load<br>rating per<br>tyre<br>[kg] (*) | Maximum<br>permissible<br>weight per<br>axle<br>[kg] (*) | Maximum<br>permissible<br>weight of the<br>vehicle (axles)<br>[kg] (*) |
| 1                            | 1       | 10.0/75-15,3 130 A8  | 550                        | 2130  | 1680   | 4200   |
| 1                            | 2       | 10.0/75-15,3 130 A8  | 550                        | 2130  | 2520   |  |

\* For speed 30 kph

- Load index must be in compliance with axle load.
- An increase in load capacity of tyre vehicles with reduced vehicle speed can be used, see Regulation 2015/208 / EU.
- Other tires that match the dimensions, load capacity and type approval may also be used.

| Checking the tyre pressure  |                                 |   |  |  |   |  |
|---|---------------------------------|---|--|--|---|--|
| Transport axle  | 10.0/75-15,3<br>pressure 550kPa | X |  |  | X |  |
| Tracing wheels  | 10.0/75-15,3<br>pressure 550kPa |   |  |  |   |  |
| <b>Transport axle bearings</b> – check and adjust allowance if needed (in the workshop) |                                 |   |  |  | X |  |

## MAINTENANCE PLAN

Perform the planned maintenance according to the instructions:

| Maintenance Task   | Daily<br>(season) | Once a<br>week | Before<br>season | After<br>season | Time<br>interval |
|--|-------------------|----------------|------------------|-----------------|------------------|
| <b>Electric cables</b>   |                   |                |                  |                 |                  |
| Check for any damage, replace if needed  |                   | X              | X                |                 |                  |
| <b>Safety measures</b>   |                   |                |                  |                 |                  |
| <b>Lighting and safety hatched boards</b> – check the condition, function and cleanliness  | X                 |                | X                |                 |                  |
| <b>Hazard and safety labels</b> – check that they are installed and legible  |                   | X              |                  |                 |                  |
| <b>Machine lubrication plan</b>  |                   |                |                  |                 |                  |
| <b>Drawbar joint / lifting loop</b> – grease   | X                 |                |                  | X               |                  |
| <b>Handbrake bolt</b> – grease or suitable oil   | X                 |                |                  | X               |                  |
| <b>Axle bearings</b> – grease with Lithium content – check, refill if needed   |                   |                |                  | X               |                  |
| <b>After season</b>  |                   |                |                  |                 |                  |
| <b>Entire machine</b>  |                   |                |                  |                 |                  |
| <ul style="list-style-type: none"> <li>• Treat and clean the machine; do not spray oil or similar agents on the plastic parts</li> <li>• Spray the piston-rods of the hydraulic cylinders with suitable anti-corrosion agents</li> <li>• Check the tightness of all bolt and plug-in connections (see the torque chart)</li> <li>• Check for any damage of the electric cables and replace if needed</li> </ul>  |                   |                |                  |                 |                  |
| <b>Brake system</b>  |                   |                |                  |                 |                  |
| <ul style="list-style-type: none"> <li>• Preserve the anti-freeze fluid for air-brake systems (about 0.1l), ethanol-free, before the last ride, use fluid recommended by the tractor manufacturer.</li> <li>• Secure the machine against movement by Scotch blocks.</li> <li>• Release the parking brake, release air from the air nozzle and close the brake lines. The service brake must be released during winter so that it does not get stuck on the brake drum</li> </ul> |                   |                |                  |                 |                  |
| <b>Points of lubrication</b>   |                   |                |                  |                 |                  |
| Grease the points of lubrication according to the lubrication plan, use grease<br><b>KP2P-20 Likx, under DIN 51 502</b>  |                   |                |                  |                 |                  |
| <b>!!! PREVENTION means removing the problem according to the plan, outside the season, without stress and comfortably before a secondary problem, an accident or a health hazard arises.</b>  |                   |                |                  |                 |                  |



## 7. MACHINE STORAGE

Long-term machine shutdown:

- Store the machine under a roof if possible.
- Store the machine on a flat and solid surface with sufficient load capacity.
- Clean the machine before storing and conserve so that it is not damaged in any way during storage. Pay special attention to all marked lubrication points and properly lubricate them according to the lubrication plan.
- Store the machine in the position with folded frames in the transport position. Store the machine on the axle and the storage leg, secure the machine against spontaneous movement using scotches or another suitable tool.  
When storing, lower the machine into the lower position using hydraulics.
- To control the axle of the **VERSO 6-7** machines in the transport position, the side frames must be slightly unfolded using the red circuit.
- The machine must not rest on the working units as it could cause damage to the working bodies of the machine.
- Secure the machine against access of unauthorised persons.

## 8. MACHINE LUBRICATION SCHEDULE

➤ During machine maintenance and its lubrication, it is necessary to observe the safety regulations.

Table 4 – Locations and Intervals of the Machine Lubrication

| LUBRICATION POINT            |       | INTERVAL   | LUBRICANT      |
|------------------------------|-------|--|----------------|
| Main Axle Support            | Fig.6 | - Always after the end of the season and before storing the machine                          | Plastic grease |
| Swivelling Axle Support      | Fig.7 | - Always after 400 ha<br>- Always after the end of the season and before storing the machine |                |
| Flexi-board Drawbar Bearings | Fig.8 | - Always after 400 ha<br>- Always after the end of the season and before storing the machine |                |

Fig.6- Lubrication the main axle support

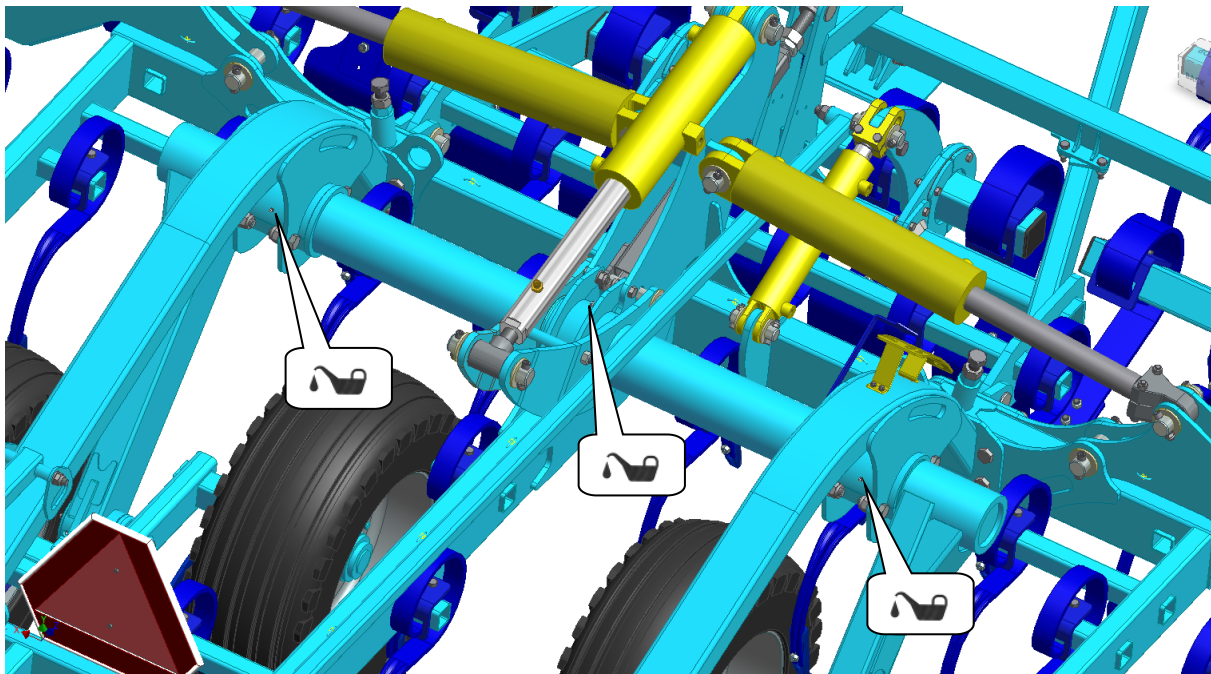

Fig.7-Lubrication the swivelling axle support

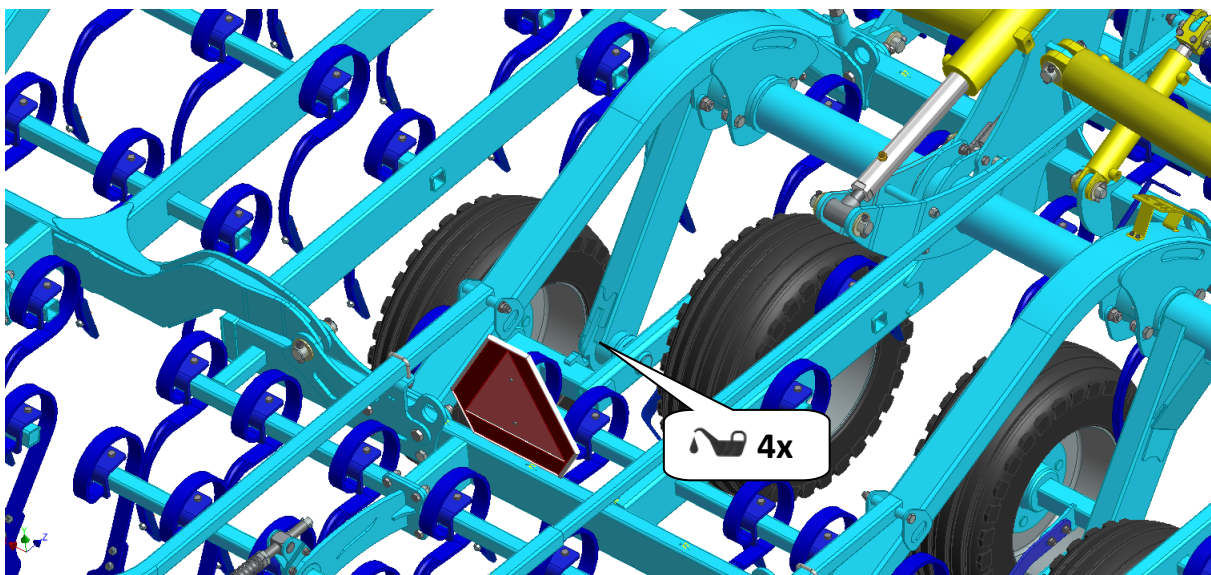
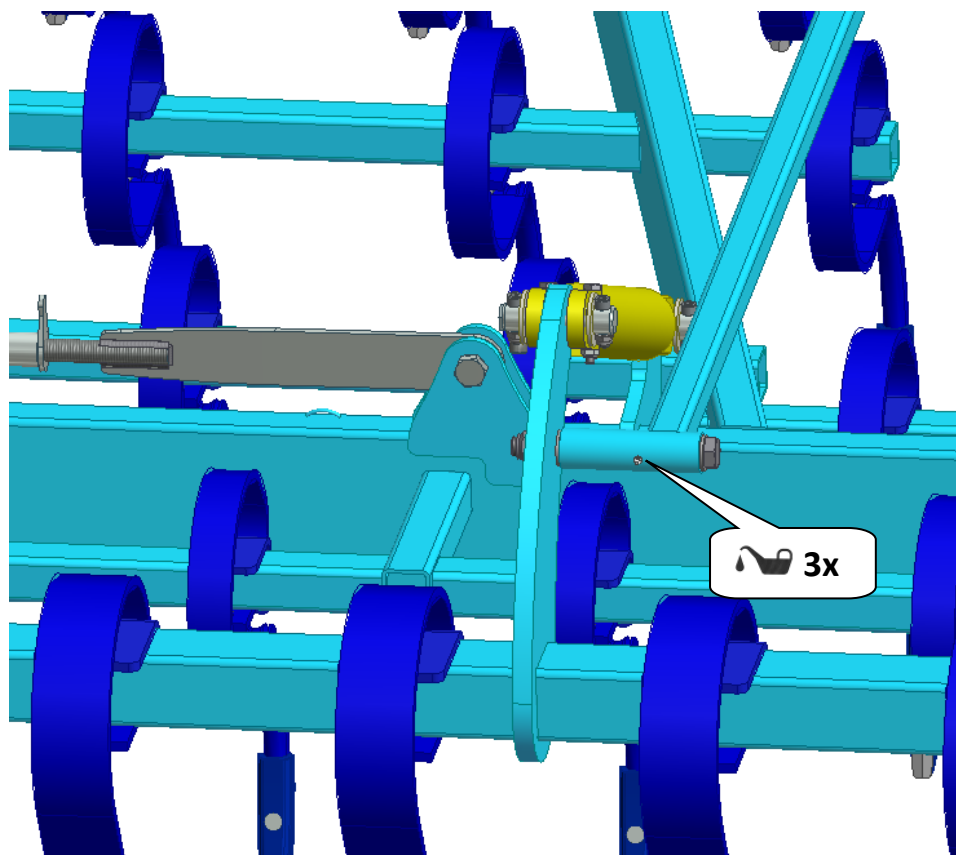

Fig.8-Lubrication of the Flexi-board drawbar



### Lubricant handling:

Protect yourselves against direct contact with oils by using gloves or protective creams. Thoroughly wash oil spots on the skin using warm water and soap. Do not clean the skin with petrol, engine diesel fuel or other solvents.

Oil is poisonous. If you swallowed the oil, immediately seek a physician.

- Protect the lubricants against children.

## **9. ENVIRONMENTAL PROTECTION**

- Regularly check the tightness of the hydraulic system.
- Preventively replace or repair hydraulic hoses, possibly further parts of the hydraulic system showing signs of damage before oil leaks occur.
- Check the condition of hydraulic hoses and perform their timely replacement. The service life of hydraulic hoses includes the time when they were stored.
- Handle oils and greases according to valid waste laws and regulations.

## **10. MACHINE DISPOSAL AFTER SERVICE LIFE EXPIRY**

- The operator must secure during machine disposal that steel parts and parts, in which hydraulic oil or lubricating grease moves are differentiated.
- Steel parts must be cut by the operator while observing safety regulations and handed over to the secondary raw material collection point. He must proceed with other parts according to valid laws about waste.

## **11. SERVICING AND WARRANTY CONDITIONS**

### **11.1 SERVICING**

Servicing is secured by the dealer after consulting with the manufacturer, possibly directly by the manufacturer. Spare parts then using the sales network by individual sellers in the entire country. Use only the spare parts according to the spare parts catalogue officially issued by the manufacturer.

### **11.2 WARRANTY**

- 11.2.1** The manufacturer provides a warranty of 24 months for these machine parts: main frame, axle, and machine tow bar. For other parts of the machine, the manufacturer provides a warranty of 12 months. The warranty is provided from the date of sale of the new machine to the end user (consumer).
- 11.2.2** The warranty applies to hidden defects that will show in the warranty period with proper use of the machine and while fulfilling the conditions stated in the operating manual.
- 11.2.3** The warranty does not apply to wearable spare parts, i.e. regular mechanical wear and tear of replaceable parts of the working sections (shares, edges, etc.).
- 11.2.4** The warranty does not apply to indirect consequences of possible damage, such as service life decrease etc.
- 11.2.5** The warranty is bound to the machine and is not void upon an owner change.
- 11.2.6** The warranty is limited to the disassembly and assembly, possibly replacement or repair of the defective part. The decision, whether to replace or repair the defective part, is up to the contractual workshop of Farmet.
- 11.2.7** During the warranty period, only the authorised servicing technician of the manufacturer may perform repairs or other interventions into the machine. In the opposite case, the warranty will not be acknowledged. This provision does not apply to the replacement of wearable spare parts (see point 11.2.3).
- 11.2.8** The warranty is conditioned by using the genuine spare parts of the manufacturer.

ⒸES PROHLÁŠENÍ O SHODĚ  
ⒸCE CERTIFICATE OF CONFORMITY  
ⒸEG-KONFORMITÄTSEKTLÄRUNG  
ⒸDÉCLARATION CE DE CONFORMITÉ  
ⒸСЕРТИФИКАТ СООТВЕТСТВИЯ ЕС  
ⒸDEKLARACJA ZGODNOŚCI WE

1. ⒸMy ⒸWe ⒸWir ⒸNous ⒸМы ⒸMy: **Farmet a.s.**  
Jiřinková 276  
552 03 Āeská Skalice  
Czech Republic  
DIĀ: CZ46504931  
Tel/Fax: 00420 491 450136

ⒸVydáváme na vlastní zodpovědnost toto prohlášení. ⒸHereby issue, on our responsibility, this Certificate. ⒸGeben in alleiniger Verantwortung folgende Erklärung ab. ⒸPublions sous notre propre responsabilité la déclaration suivante. ⒸПод свою ответственность выдаем настоящий сертификат. ⒸWydajemy na własną odpowiedzialność niniejszą Deklarację Zgodności.

2. ⒸStrojní zařízení: - název : **Kultivátor**  
ⒸMachine: - name : **Cultivator**  
ⒸFabrikat: - Bezeichnung : **Kultivator**  
ⒸMachinerie: - dénomination : **Cultivateur**  
ⒸСельскохозяйственная машина: - наименование : **Культиватор**  
ⒸUrządzenie maszynowe: - nazwa : **Spulchniarka**

- typ, type : **VERSO**  
- model, modèle : **VERSO 6 PS | 7 PS | 8 PS | 9 PS**  
- PIN/VIN :

- Ⓒvýrobní číslo :   
- Ⓒserial number  
- ⒸFabriknummer  
- Ⓒn° de production  
- Ⓒзаводской номер  
- Ⓒnumer produkcyjny:

3. ⒸPřislušná nařizení vlády: Ā.176/2008 Sb. (směrnice 2006/42/ES). ⒸApplicable Governmental Decrees and Orders: No.176/2008 Sb. (Directive 2006/42/ES). ⒸEinschlägige Regierungsverordnungen (NV): Nr.176/2008 Slg. (Richtlinie 2006/42/ES). ⒸDécrets respectifs du gouvernement: n°.176/2008 du Code (directive 2006/42/CE). ⒸСоответствующие постановления правительства: № 176/2008 Сб. (инструкция 2006/42/ES). ⒸOdpowiednie rozporządzenia rządowe: nr 176/2008 Dz.U. (Dyrektywa 2006/42/WE).

4. ⒸNormy s nimiž byla posouzena shoda: ⒸStandards used for consideration of conformity: ⒸDas Produkt wurde gefertigt in Übereinstimmung mit folgenden Normen: ⒸNormes avec lesquelles la conformité a été évaluée: ⒸНормы, на основании которых производилась сертификация: ⒸNormy, według których została przeprowadzona ocena: ĀSN EN ISO 12100, ĀSN EN ISO 4254-1.

ⒸSchválil ⒸApprove by dne: 01.12.2021  
ⒸBewilligen ⒸApprouvé  
ⒸУтвердил ⒸUchwalit

V Āeské Skalici dne: 01.12.2021

Ing. Petr Lukářek  
technický ředitel  
Technical director

Ing. Karel Źďárský  
generální ředitel společnosti  
General Manager

  
**Farmet a.s.**  
Jiřinková 276  
552 03 Āeská Skalice  
DIĀ CZ46504931  
59